

Video Panel (A) Schematic Diagram & Waveforms for Diagram (A)

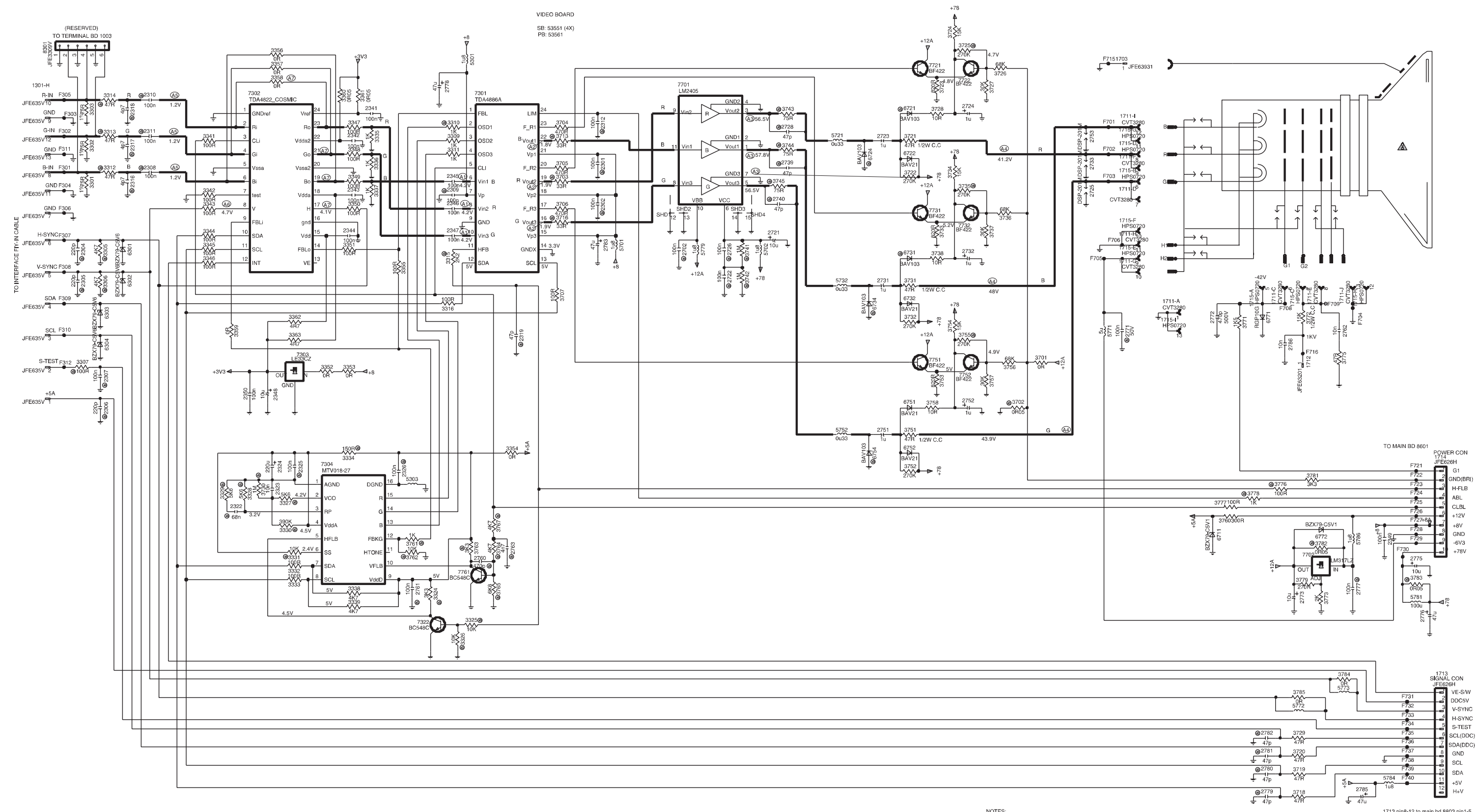

NOTES:
 ● STANDS FOR CHIP COMPONENT

1713 pin8-12 to main bd 8803 pin1-5

Deflection Schematic Diagram

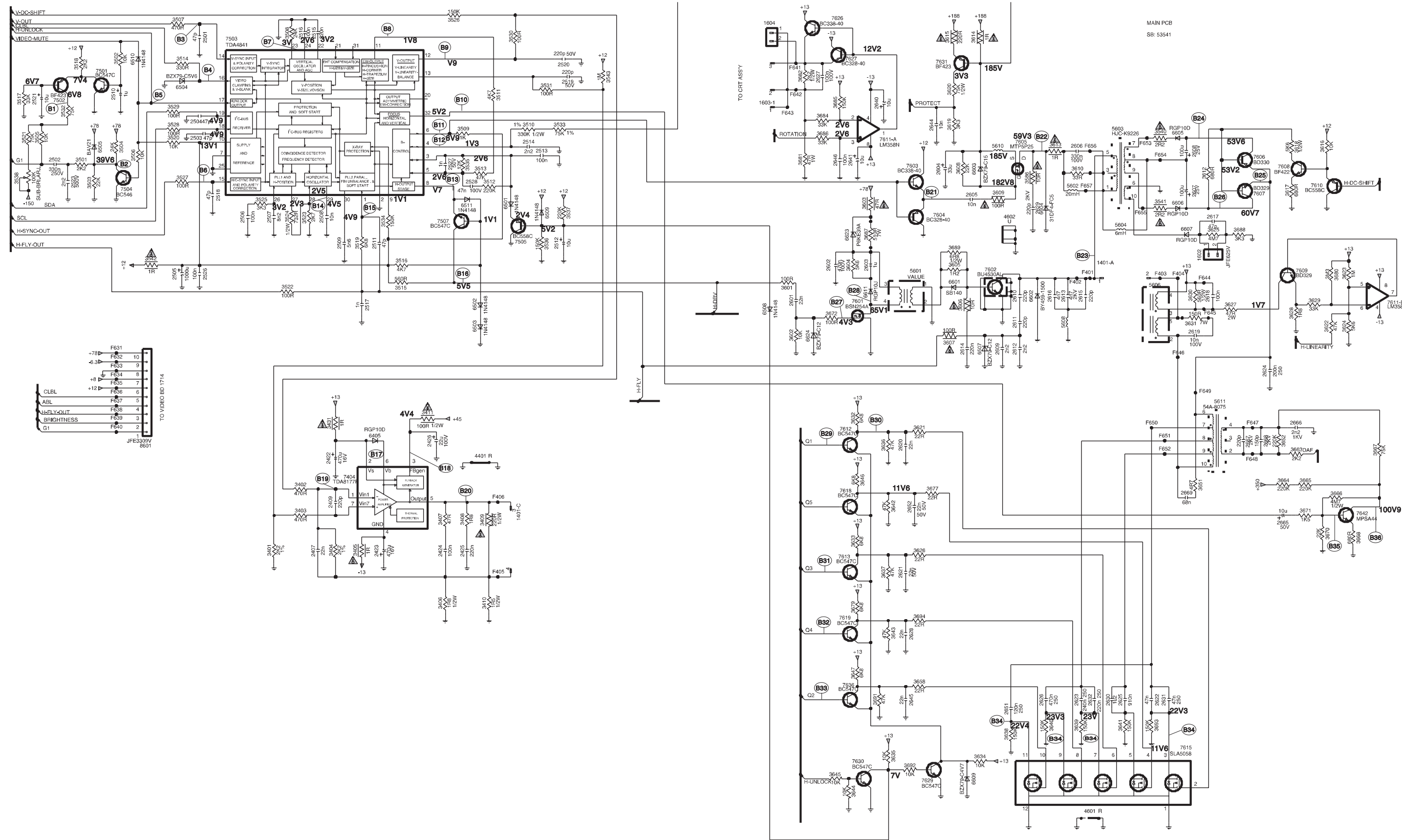

CPU Schematic Diagram

MAIN PCB
SB: 53541

