



*Personal Computer
Hardware Reference
Library*

Guide to Operations

Revised Edition (April 1984)

This product could include technical inaccuracies or typographical errors. Changes are periodically made to the information herein; these changes will be incorporated in new editions of the publication.

It is possible that this material may contain references to, or information about, IBM products (machines and programs), programming or services that are not announced in your country. Such references or information must not be construed to mean that IBM intends to announce such IBM products, programming, or services in your country.

Products are not stocked at the address below. Requests for copies of this product and for technical information about the system should be made to your authorized IBM Personal Computer dealer.

The following paragraph applies only to the United States and Puerto Rico: A Reader's Comment Form is provided at the back of this publication. If the form has been removed, address comments to: IBM Corp., Personal Computer, P.O. Box 1328-C, Boca Raton, Florida 33432. IBM may use or distribute any of the information you supply in any way it believes appropriate without incurring any obligations whatever.

© Copyright International Business Machines Corporation, 1981, 1982, 1983, 1984

FEDERAL COMMUNICATIONS COMMISSION RADIO FREQUENCY INTERFERENCE STATEMENT

Warning: The equipment described herein has been certified to comply with the limits for a Class B computing device, pursuant to Subpart J of Part 15 of FCC rules. Only peripherals (computer input/output devices, terminals, printers, etc.) certified to comply with the Class B limits may be attached to this computer. Operation with noncertified peripherals is likely to result in interference to radio and TV reception. If peripherals not offered by IBM are used with the equipment, it is suggested to use shielded grounded cables with in-line filters if necessary.

INSTRUCTIONS TO USER

This equipment generates and uses radio frequency energy and if not installed and used properly, i.e., in strict accordance with the operating instructions, reference manuals, and the service manual, may cause interference to radio or TV reception. It has been tested and found to comply with the limits for a Class B computing device pursuant to Subpart J of Part 15 of FCC rules, which are designed to provide reasonable protection against such interference when operated in a residential installation.

If this equipment does cause interference to radio or TV reception, which can be determined by turning the equipment off and on, the user is encouraged to try to correct the interference by one or more of the following measures:

- Reorient the receiving antenna.
- Relocate the equipment with respect to the receiver.
- Move the equipment away from the receiver.
- Plug the equipment into a different outlet so that equipment and receiver are on different branch circuits.
- Ensure that card mounting screws, attachment connector screws, and ground wires are tightly secured.
- Ensure that card slot covers are in place when no card is installed.
- If peripherals not offered by IBM are used with this equipment, it is suggested to use shielded, grounded cables, with in-line filters if necessary.

If necessary, consult your dealer service representative for additional suggestions.

The manufacturer is not responsible for any radio or TV interference caused by unauthorized modifications to this equipment. It is the responsibility of the user to correct such interference.

CAUTION

This product is equipped with a line cord and plug for the user's safety. It is to be used in conjunction with a properly grounded receptacle to avoid electrical shock.

Preface

The *Guide to Operations* manual provides the information you need to install and operate your IBM Personal Computer XT, and to diagnose and correct many problems that may occur. The manual consists of six sections, each with an external tab to help you find the section you want. A description of each section follows.

SECTION 1, INTRODUCTION AND INSTALLATION, provides a brief description of the system unit, keyboard, printers, expansion unit, and displays. It also shows a typical system arrangement. Cabling of the system is shown, and the power-on self test is described.

SECTION 2, PROBLEM DETERMINATION PROCEDURES, describes the steps to correct problems that may occur.

SECTION 3, OPERATING YOUR PERSONAL COMPUTER XT, shows the location and describes the operation of the power switches, describes the keyboard, and explains the operation of the various units of the system.

SECTION 4, OPTION INSTALLATION, is where you file the installation instructions that come with any option you purchase for your system. This section also has charts showing how to set switches for your particular system arrangement.

SECTION 5, MOVING YOUR IBM PERSONAL COMPUTER XT, describes how to prepare your system when you have to move it.

SECTION 6, TEMPLATES, provides graphic layouts of keyboards for use with international keyboards and National DOS.

A glossary of terms and abbreviations used in the manual is also included.

Contents

SECTION 1. INTRODUCTION AND INSTALLATION	1-1
Introduction	1-3
Example of a System Arrangement	1-4
Option Examples	1-5
Handling Diskettes	1-7
Installation	1-9
System Cabling	1-14
Keyboard Tilt Adjustment	1-15
Power-On Self Test	1-16
Screen Alignment Procedure	1-20
Summary	1-24
SECTION 2. PROBLEM DETERMINATION PROCEDURES	2-1
SECTION 3. OPERATING YOUR IBM PERSONAL COMPUTER XT	3-1
System Unit	3-3
Keyboard	3-5
The Typewriter Area	3-6
The Numeric Keypad	3-10
Function Keys	3-14
Diskette Drive	3-15
Expansion Unit	3-17
IBM Monochrome Display	3-18
IBM Color Display	3-19
Power-On Control	3-19
Contrast Control	3-19
Brightness Control	3-19
Vertical Hold Control	3-20
Vertical Size Control	3-21
SECTION 4. OPTION INSTALLATION	4-1
How to Use This Section	4-3
Handling Static-Sensitive Devices	4-4
System Board Switches	4-7

Coprocessor	4-8
Memory	4-8
Displays	4-9
5-1/4 Inch Diskette Drives	4-10
Memory Option Switches	4-11
288K Total Memory	4-11
320K Total Memory	4-11
352K Total Memory	4-12
384K Total Memory	4-13
416K Total Memory	4-14
448K Total Memory	4-15
480K Total Memory	4-16
512K Total Memory	4-17
544K Total Memory	4-18
576 Total Memory	4-19
608 Total Memory	4-20
640K Total Memory	4-21
Extender Card Switches	4-22

SECTION 5. MOVING YOUR IBM PERSONAL

COMPUTER XT	5-1
Preparing the System	5-3
Short Distance Move	5-8
Long Distance Move	5-9
All Units	5-9
System Unit	5-9
Expansion Unit	5-10
Keyboard	5-11
IBM Monochrome or Color Display ..	5-12
IBM Graphics Printer	5-13
Installation at New Location	5-14

SECTION 6. KEYBOARD TEMPLATES

Introduction	6-3
French	6-5
German	6-7
Italian	6-9
Spanish	6-11
U.K. English	6-13
U.S. English	6-15

GLOSSARY

Glossary-1

INDEX Index-1

Notes:

SECTION 1. INTRODUCTION AND INSTALLATION

Contents

Introduction	1-3
Example of a System Arrangement	1-4
Option Examples	1-5
Handling Diskettes	1-7
Installation	1-9
System Cabling	1-14
Keyboard Tilt Adjustment	1-15
Power-On Self Test	1-16
Screen Alignment Procedure	1-20
Summary	1-24

Notes:

Introduction

The basic IBM Personal Computer XT consists of a system unit and keyboard. The system unit has a 10M-byte fixed disk drive, a dual-sided diskette drive, an Asynchronous Communications Adapter, 128K bytes of memory, and five expansion slots. The keyboard, which is what you use to send data to your system, attaches to the system unit with a 2-meter (6-foot) coiled cable. The keyboard consists of three major sections: the typewriter area, the numeric keypad, and the function keys.

You can add various options to your system—a display, a printer, an expansion unit, a fixed disk drive, memory, and more.

The IBM Personal Computer XT is designed for use with monitors or televisions that meet either the National Television System Committee (NTSC)¹ or the Electronics Industry Association (EIA) RS 170 standards. Therefore, if your device does not meet these standards, it may not function properly.

Several printers are available for printout or hard-copy of your data files. The IBM Graphics Printer and the IBM Color Printer provide bidirectional printing in several character sizes on single- or multi-part forms. A Compact Printer is also available at a very attractive price.

The expansion unit provides space for additional options to be attached to your IBM Personal Computer XT. The expansion unit comes equipped with a 10M-byte fixed disk drive and after installation, contains two 10M-byte fixed disk drives and six available expansion slots.

¹ The National Television System Committee has set United States broadcast standards.

Example of a System Arrangement

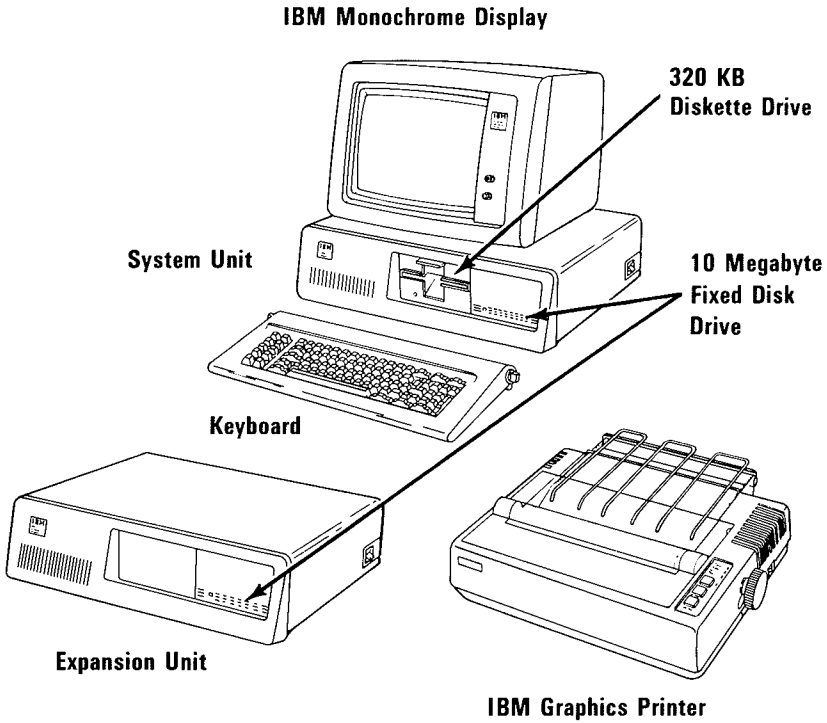

Option Examples

These are options which you can add externally to your system.

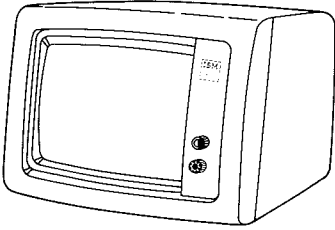

IBM Monochrome Display

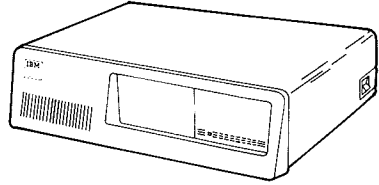

Expansion Unit

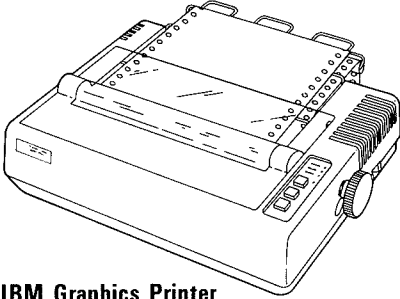

IBM Graphics Printer

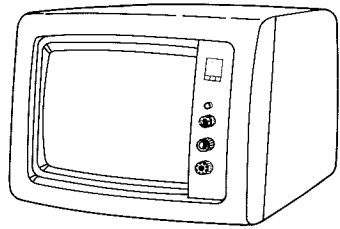

IBM Color Display

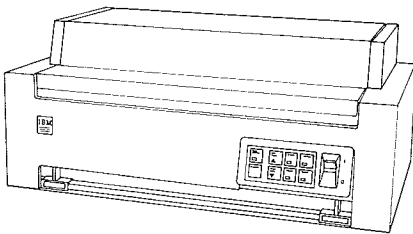

IBM Color Printer

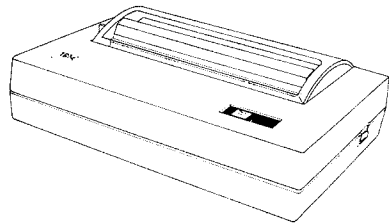

IBM Compact Printer

Option Examples

These are some of the options which you can install in your system unit or expansion unit.

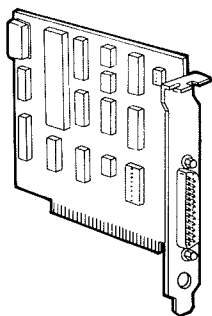

Asynchronous Communications Adapter

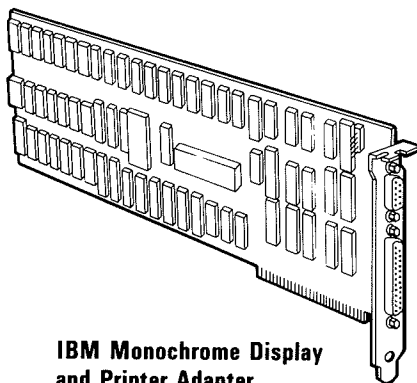

IBM Monochrome Display and Printer Adapter

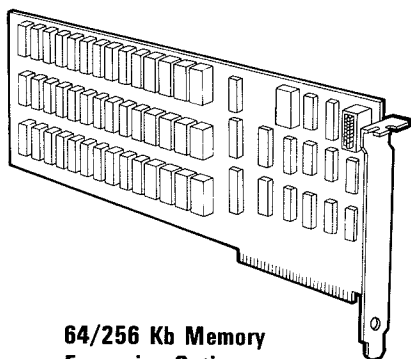

64/256 Kb Memory Expansion Option

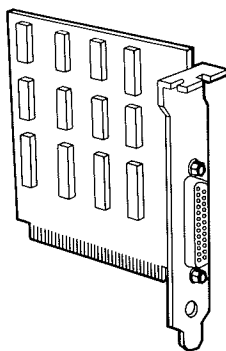

Printer Adapter

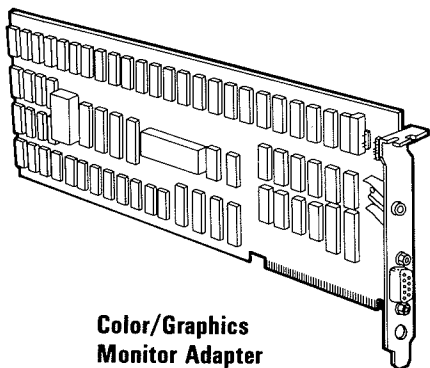

Color/Graphics Monitor Adapter

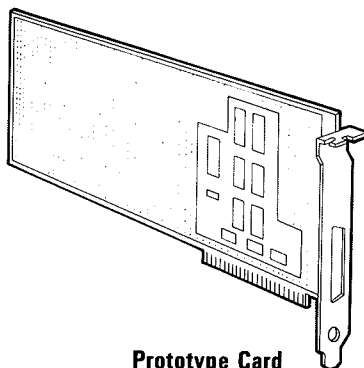

Prototype Card

Handling Diskettes

The figures below show some proper and improper ways of handling your diskettes. Proper handling greatly reduces the possibility of damage.

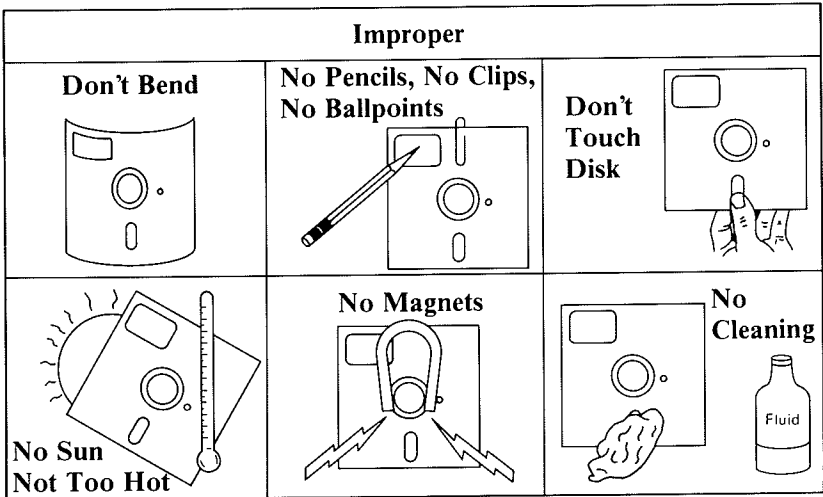
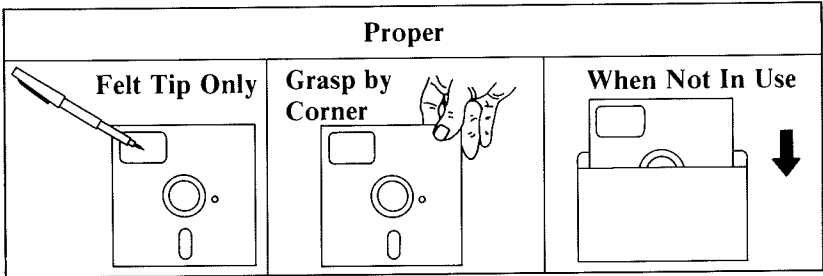

Notes:

1-8 Introduction

Installation

To install your IBM Personal Computer XT, do the following.

- 1 Remove the tape from the diskette drive.

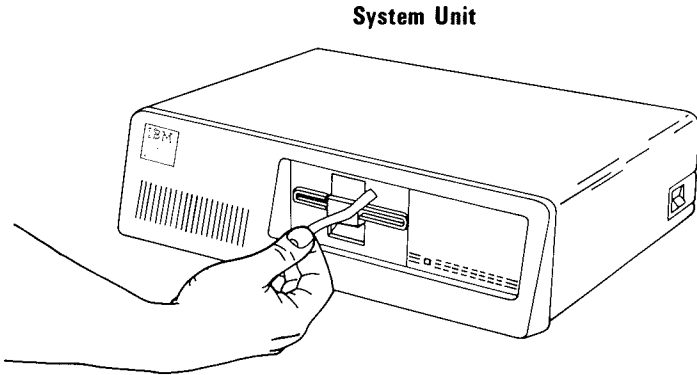

- 2 Remove the shipping cardboard.

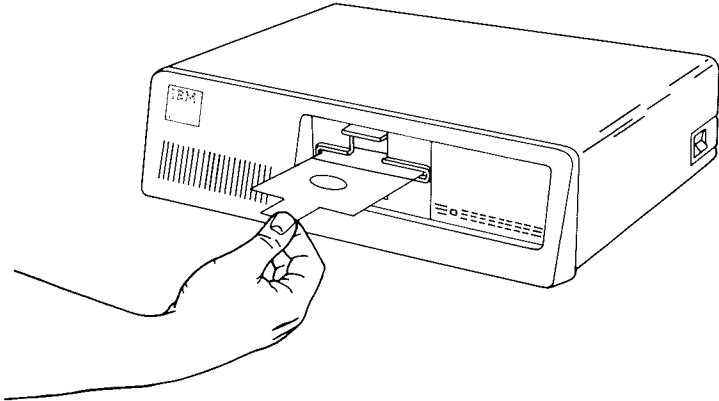

Note: Save the shipping cardboard. You may need it to insert into the diskette drive if you transport your system in the future.

- 3** Place the system unit in the position shown.

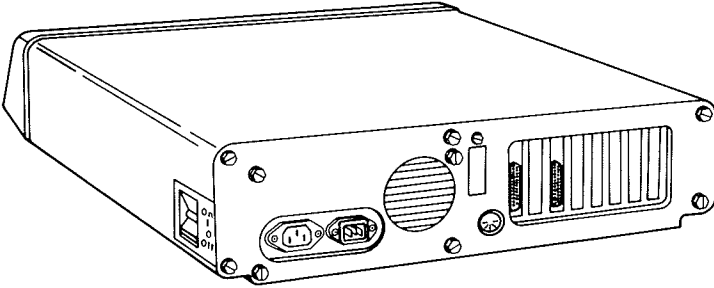

- 4** Connect the keyboard cable to the system unit.

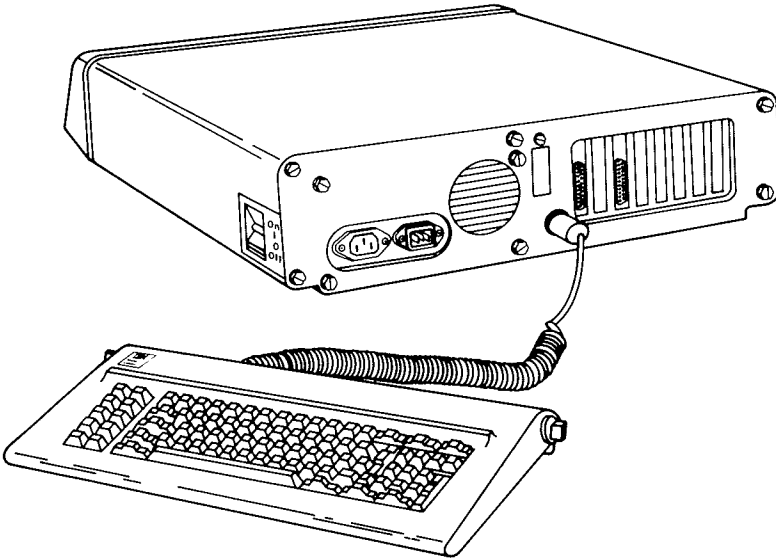

- 5** Set the system unit's Power switch to Off.

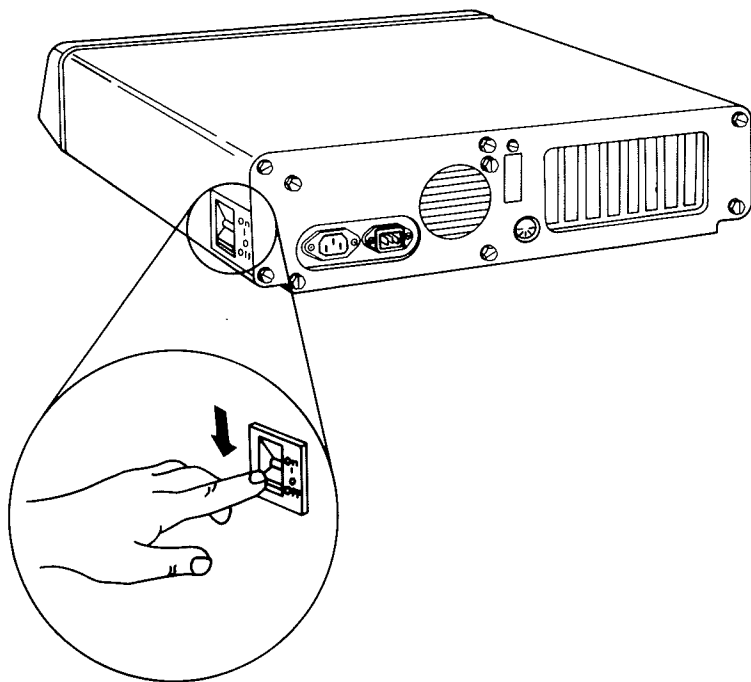

| Is the International symbol for On.

○ Is the International symbol for Off.

- 6** Connect the system power cord to the system unit, then to the wall outlet.

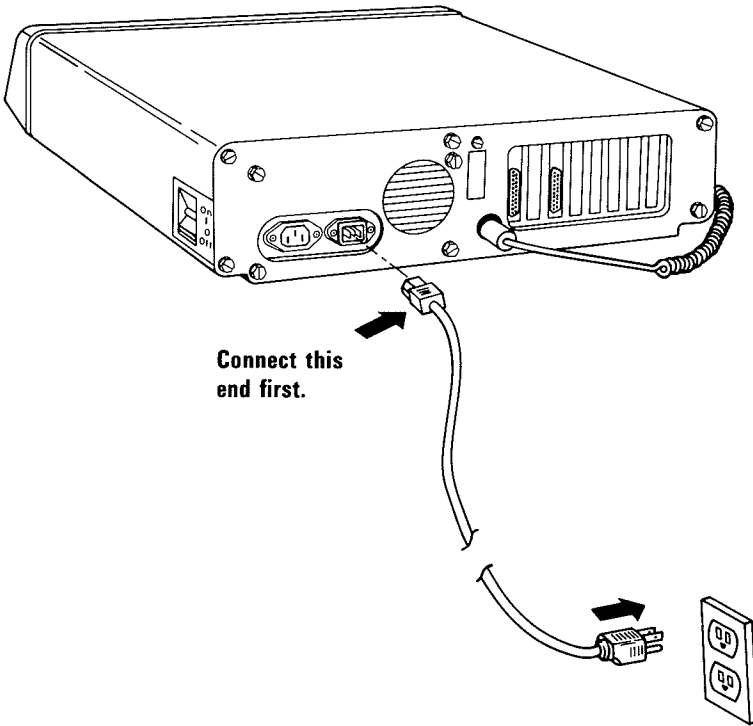

CAUTION

This product is equipped with a line cord and plug designed for the user's safety. It is to be used with a properly grounded power receptacle to avoid possible electrical shock.

7

Set the Power switch to On. You should hear one short beep after a short system test.

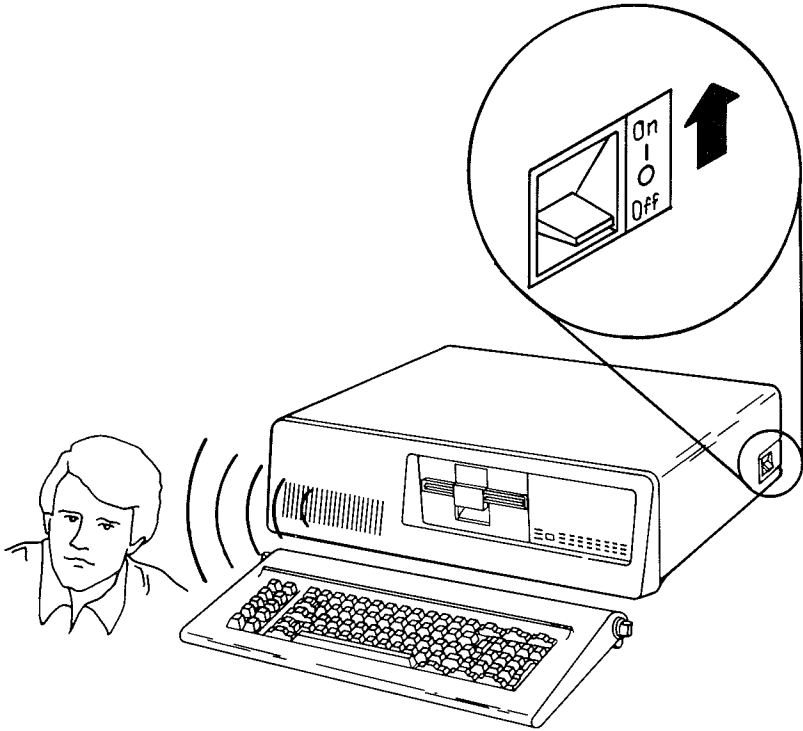

If you do not hear the short beep, check the wall outlet by plugging in a working lamp. If the lamp lights, return your IBM Personal Computer XT to your place of purchase.

If you hear the short beep, your system unit has completed its self-test.

You are now ready to install your options. Be sure to read "Handling Static-Sensitive Devices" in the "Option Installation" section of this manual before installing an option in your IBM Personal Computer XT. If your options are already installed, continue with "System Cabling."

System Cabling

Connect your cables and Power cords to the system unit, as shown in the following figure.

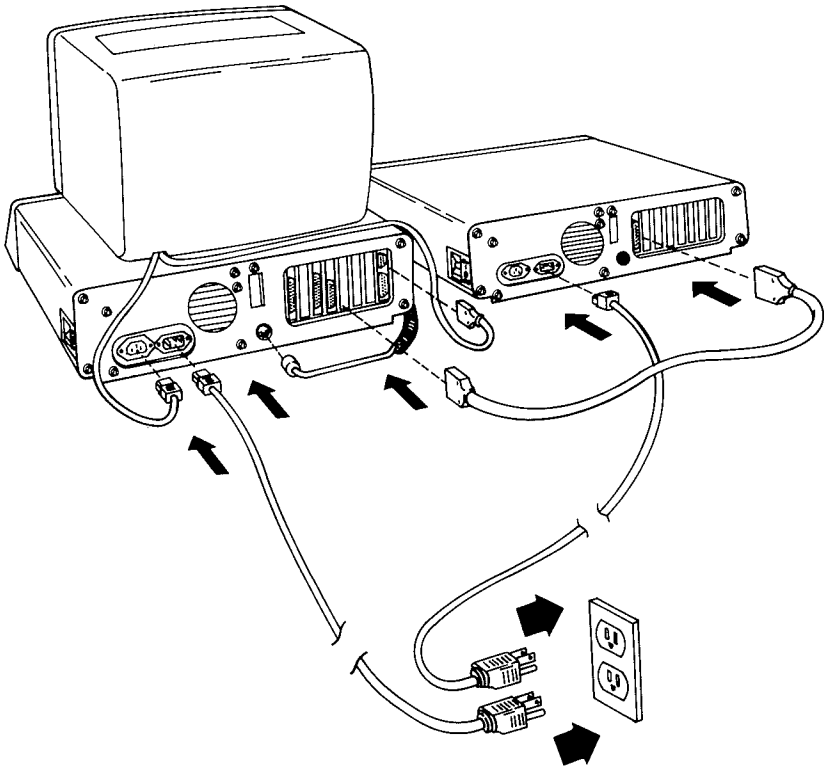

CAUTION

This product is equipped with a line cord and plug designed for the user's safety. It is to be used with a properly grounded power receptacle to avoid possible electrical shock.

Note: If you are using your TV or a non-IBM display, you could experience data errors while using your diskette drive. This interference can easily be corrected by moving your TV or display at least 30 cm (12 inches) away from your IBM Personal Computer XT.

Keyboard Tilt Adjustment

The tilt of the keyboard can be adjusted for your typing comfort. To adjust the tilt, hold the keyboard, firmly push in the adjustable foot handles and turn them to the desired tilt position, as shown below.

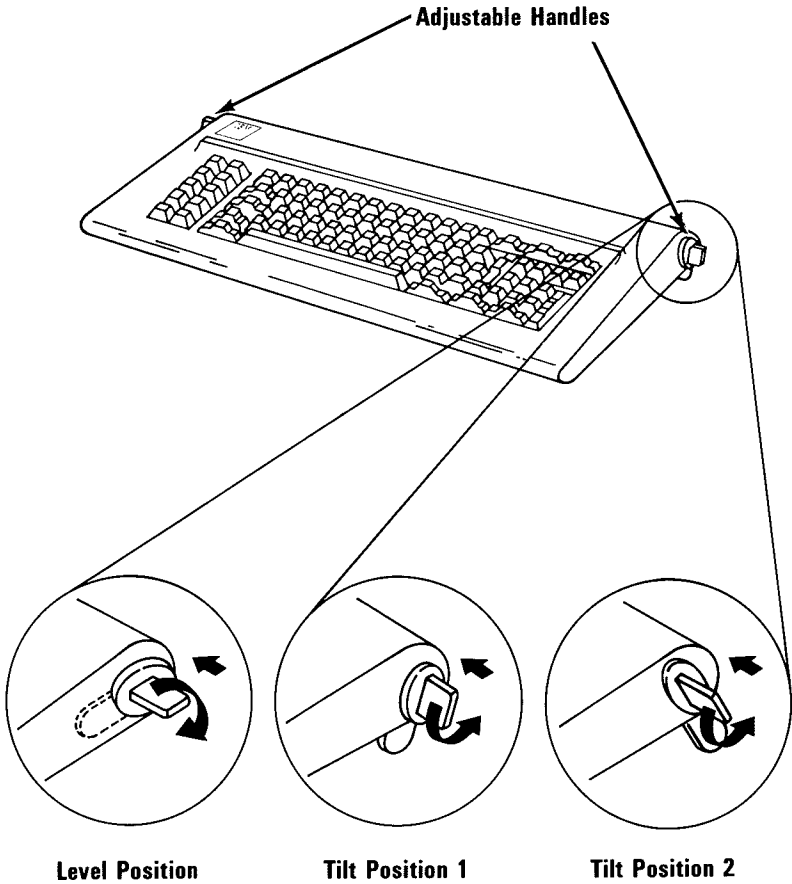

Note: Tilt position 1 may not be available on your keyboard.

Power-On Self Test

The power-on self test (POST) is done each time your system's power is switched on. The POST takes 13 to 90 seconds, depending on the amount of memory in your system.

- 1** Turn the Contrast and Brightness controls on your display or TV fully clockwise.
- 2** Switch on the power to all attached devices (printer, TV, etc.).
- 3** Set the Power switch on the expansion unit (if attached) to On.
- 4** Set the Power switch on the system unit to On. There are normally three responses.
 - A** An indication of the memory test appears in the upper-left corner of your screen. The number should continue to increase until it equals the amount of memory in your system.



XXX KB OK

- B** One short beep is heard at the end of the POST.

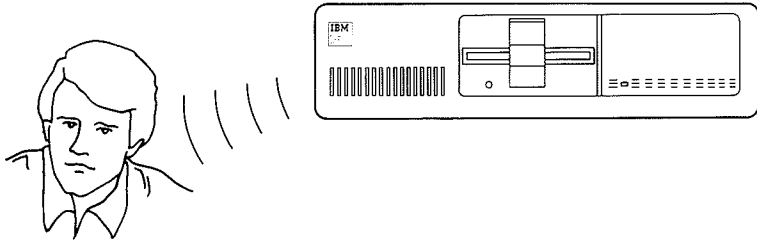

- C** The IBM Personal Computer BASIC message and a blinking cursor appear unless a program from a diskette, or an operating system from the fixed disk drive, is loaded. Then the first presentation of the program or operating system appears.

**The IBM Personal Computer Basic
Version CX.XX Copyright IBM Corp. XXXX
XXXXX Bytes free
Ok**

1LIST 2RUN 3LOAD" 4SAVE 5CONT 6LPT1 '7TRON 8TROFF 9KEY 0SCREEN

If the responses are not correct, go to "Problem Determination Procedures."

Note: If you are using your TV or a non-IBM display, and the screen image is similar to the one below, the screen needs alignment. The procedure for doing this appears later in this section. For now, continue with Step 5.

IBM Personal Computer Basic
Version X.XX Copyright IBM Corp. XXXX
XXXX Bytes Free

1ST 2RUN 3LOAD 4SAVE 5CONT 6LPT1 7TRON 8TROFF 9KEY 0SCREEN

- 5** Adjust the Contrast and Brightness controls for eye comfort.

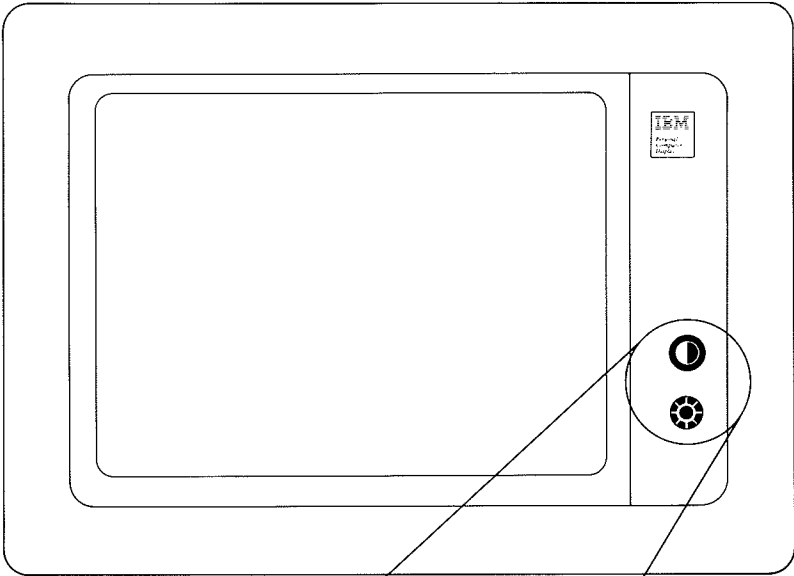

IBM Monochrome Display

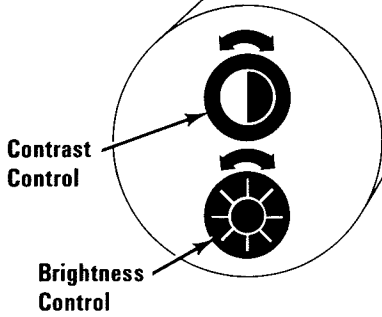

Screen Alignment Procedure

- 1** Remove the Diagnostics diskette from the back of this manual.

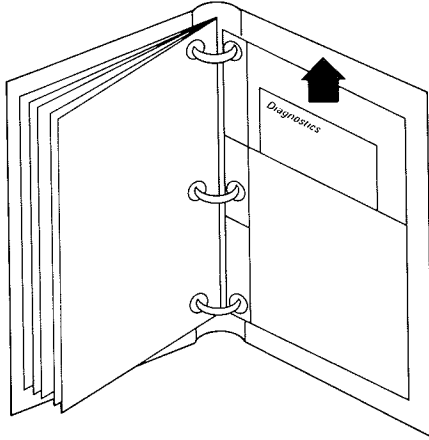

- 2** Set the Power switch on the system unit (and expansion unit, if attached) to Off.
- 3** Set the Power switches on all attached devices to Off (printer, TV, etc.).

- 4 Lift the load lever on the diskette drive.
- 5 Insert the Diagnostics diskette.
- 6 Push the load lever down.
- 7 Switch on power to all attached devices.
- 8 If an expansion unit is attached, set its Power switch to On.
- 9 Set the system unit's Power switch to On.

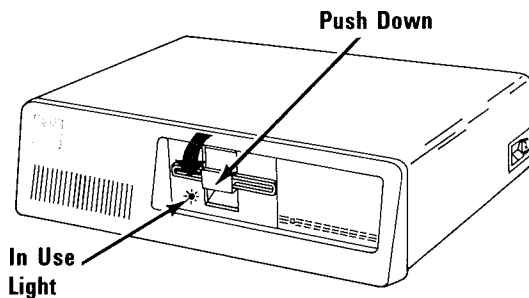
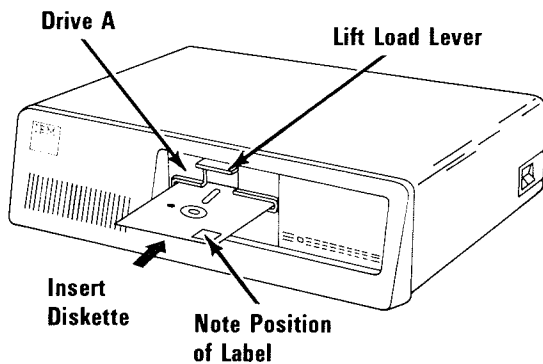



Note: If you are using your TV or a non-IBM display, and the screen image is similar to the one below, do the step on the next page to correct the problem.

e IBM Personal Computer DIAGNOSTICS
rsion X.XX (C) Copyright IBM Corp XXXX

LECT AN OPTION

- RUN DIAGNOSTIC ROUTINES
- FORMAT DISKETTE
- COPY DISKETTE
- PREPARE SYSTEM FOR RELOCATION
- EXIT TO SYSTEM DISKETTE

TER THE ACTION DESIRED

- 10** Press function key  to move the information on the screen to the right, or function key  to move the information to the left.

Your screen should match the figure below. If not, go to “Problem Determination Procedures.”

**The IBM Personal Computer DIAGNOSTICS
Version X.XX (C) Copyright IBM Corp XXXX
SELECT AN OPTION
0 - RUN DIAGNOSTIC ROUTINES
1 - FORMAT DISKETTE
2 - COPY DISKETTE
3 - PREPARE SYSTEM FOR RELOCATION
9 - EXIT TO SYSTEM DISKETTE
ENTER THE ACTION DESIRED
?**

Summary

You now have installed and arranged your IBM Personal Computer XT. You also have learned how to perform the power-on self test (POST) and what responses to expect after a successful POST. You know the proper way to handle diskettes and how to align your screen. Now you are ready to give your system a complete diagnostic test, which you should do whenever you cable your system or install an option.

Now turn to “Problem Determination Procedures” and give your system a complete diagnostic test.

SECTION 2. PROBLEM DETERMINATION PROCEDURES

Introduction

If you experience a problem with either your IBM Personal Computer or IBM Personal Computer XT, the problem determination procedures will help you find which unit in your system is failing. The procedures also can be used to check that your system is operating correctly. Simply follow the step-by-step instructions and answer yes or no to the questions asked.

As part of the problem determination, you may have to use the Diagnostics diskette, which is at the back of the manual. The diskette has a series of tests that check the five units of your system—system unit, expansion unit, keyboard, display, and printer—as well as other installed options. The tests are performed in sequence. As one test finishes successfully, the next one automatically starts.

Note: If you have a non-U.S. English keyboard and use the diskette in the back of this manual, use a U.S. English keyboard template.

For a screen-alignment problem, start on the following page. To do a complete system check or find the cause of a problem, start with “Checking Electrical Connections” on page Start 20-1.

Other Options

Some options may have separate manuals. For a description of problem diagnosis, go to that option's manual.

Notes:

Screen Alignment Procedure

- 1 Remove the Diagnostics diskette from the back of this manual.

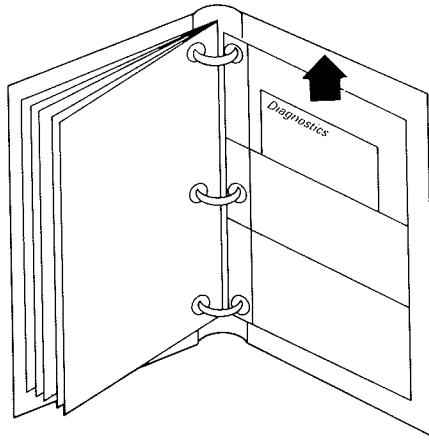

- 2 Set the Power switch on the system unit (and expansion unit, if attached) to Off.

| Is the International symbol for On.

○ Is the International symbol for Off.

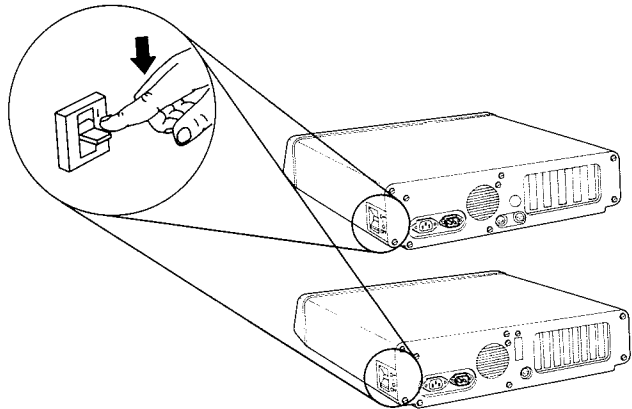

- 3** Set the Power switches on all attached devices to Off.
- 4** Lift the diskette-drive load lever.
- 5** Insert the Diagnostics diskette into drive A.

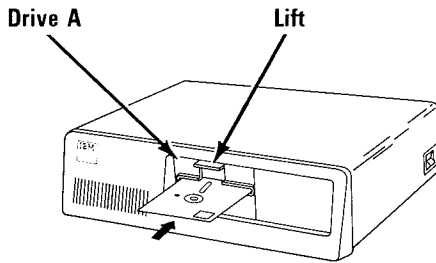

- 6** Push the load lever down.

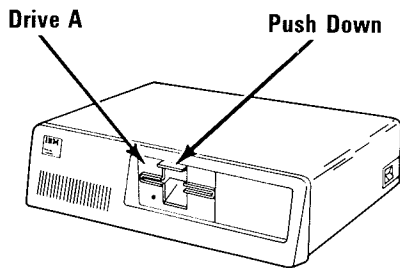

- 7 Set the Power switches on all attached devices to On.
- 8 If an expansion unit is attached, set its Power switch to On.
- 9 Set the system unit's Power switch to On.

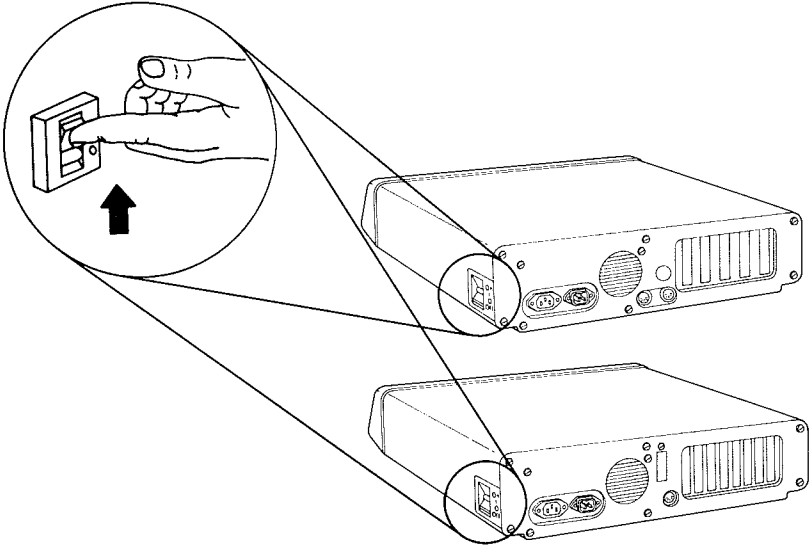

If you are using your TV or a non-IBM display with your system, and its screen image is similar to the one below, do the step following the figure to correct the problem.



Note: If the alignment on any IBM display is incorrect, have it serviced.

e IBM Personal Computer DIAGNOSTICS
rsion X.XX (C) Copyright IBM Corp XXXX

LECT AN OPTION

- RUN DIAGNOSTIC ROUTINES
- FORMAT DISKETTE
- COPY DISKETTE
- PREPARE SYSTEM FOR RELOCATION
- EXIT TO SYSTEM DISKETTE

TER THE ACTION DESIRED

10 Press function key  to move the presentation to the right, or  to move the presentation to the left, as appropriate.

Your screen should match the one shown in the figure below. If it does, remove the Diagnostics diskette and return it to the back of the manual. If not, have your TV or non-IBM display serviced.

**The IBM Personal Computer DIAGNOSTICS
Version XXX (C) Copyright IBM Corp XXXX, XXXX**

SELECT AN OPTION

- 0 - RUN DIAGNOSTIC ROUTINES**
- 1 - FORMAT DISKETTE**
- 2 - COPY DISKETTE**
- 3 - PREPARE SYSTEM FOR RELOCATION**
- 9 - EXIT TO SYSTEM DISKETTE**

ENTER THE ACTION DESIRED

?

Continue with the next Test.

Notes:

Checking Electrical Connections

- 1** Set the Power switch on the system unit (and expansion unit, if attached) to Off.
- 2** Set the Power switches on all attached devices to Off.
- 3** Disconnect all devices.
- 4** Unplug the system unit's (and expansion unit's) power cord from the wall outlet.

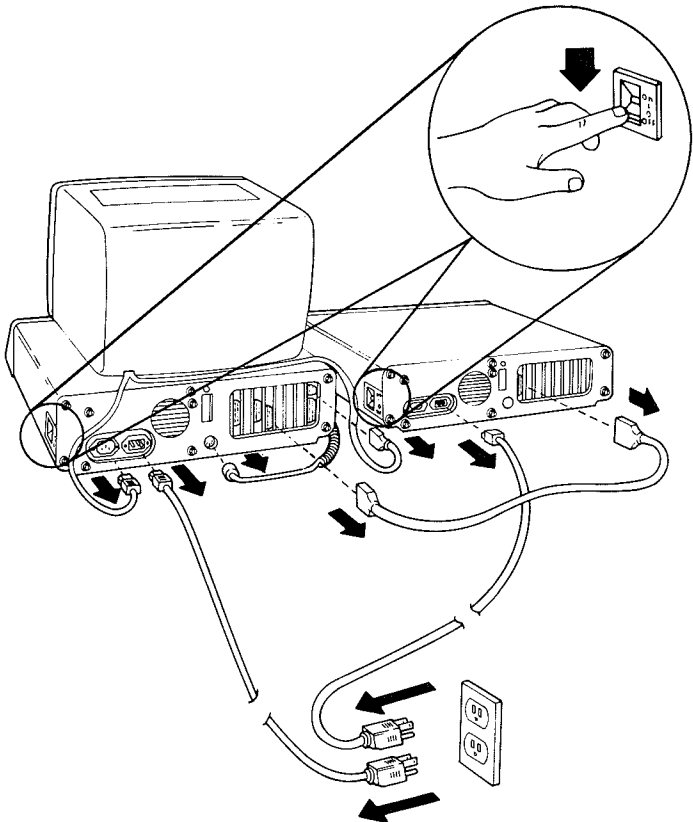

- 5** Check the wall outlet by plugging in a working lamp.

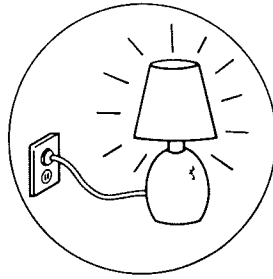

Outlet O.K.

- 6** Connect each cable to the proper connector on the system unit (and expansion unit, if attached) to ensure correct electrical connection.
- 7** Plug the system unit's (and expansion unit's) power cord into the wall outlet.

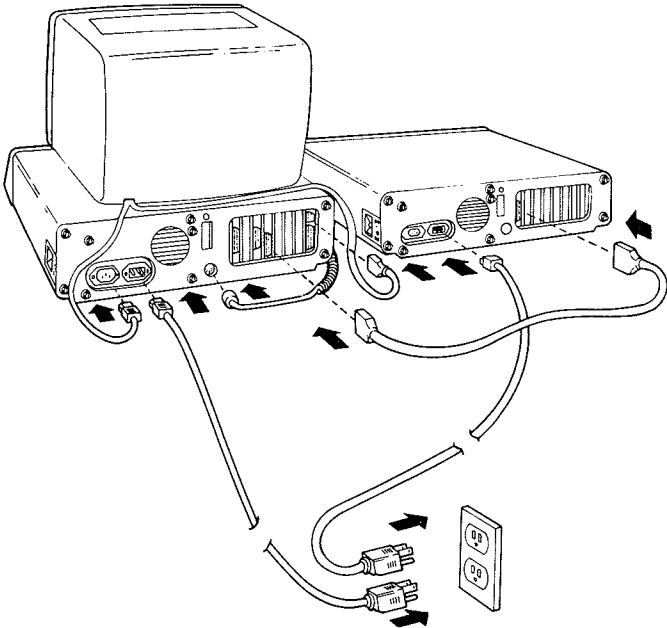

Note: If you do not have an IBM Communications Adapter Cable attached to your system unit, go to the next page.

8 If you have an IBM Communications Adapter Cable, it came with a wrap plug. Disconnect the Communications Adapter Cable at the modem end (refer to the Communications Adapter Cable's "Option Installation Instructions" for the cable-removal procedure).

9 See the figure below and install the wrap plug (IBM part number 8529280) on the modem end of the cable (end farthest from the system unit).

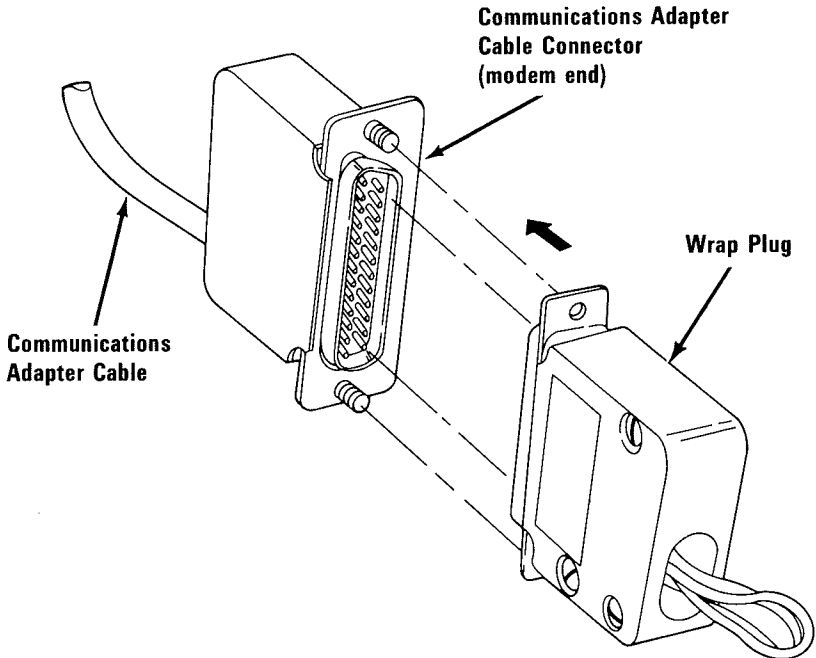

Note: If you do not have an IBM Cluster Adapter, continue with “Power-On Self Test (POST)” on the following page.

- 10** If you have an IBM Cluster Adapter, it came with a terminating plug. Disconnect the coaxial cable from the Cluster Adapter’s connector.
- 11** Refer to the figure below and install the terminating plug (IBM part number 6323481) on the Cluster Adapter’s connector.

Continue with “Power-On Self Test (POST)” on the following page.

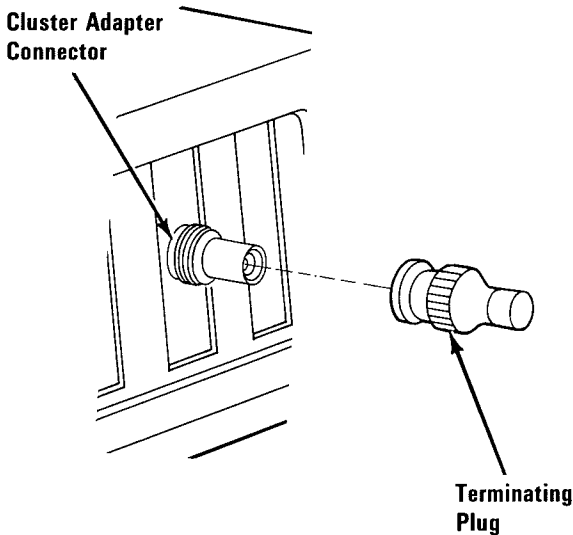

Power-On Self Test (POST)

- 1** Turn the Brightness and Contrast controls fully clockwise. When the first screen presentation appears, adjust the controls for eye comfort.

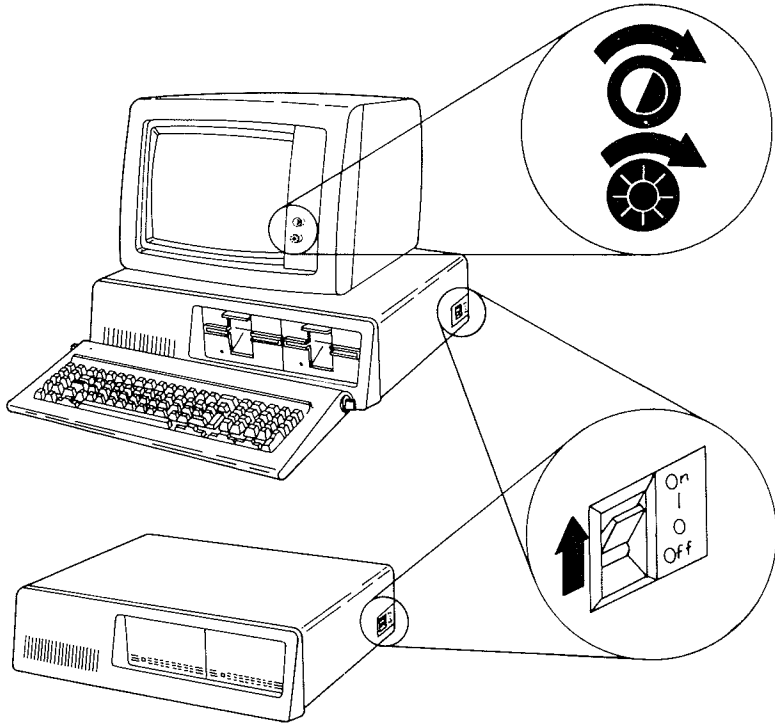

- 2** Set the Power switches on all attached devices to On.
- 3** If the expansion unit is attached, set its Power switch to On.
- 4** Set the system unit's Power switch to On.

POST will finish in 13 to 90 seconds, depending on the amount of memory in your system. Normally, you will receive the following responses:

- A Look in the upper left-hand corner of the screen during POST.

If you have the Personal Computer, a blinking cursor should appear.

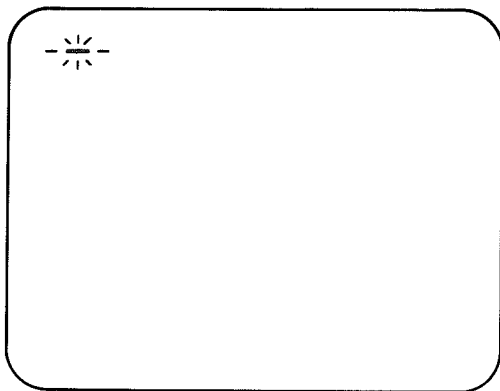

If you have the Personal Computer XT, a number should appear and continue to increase in value until it equals the amount of memory in your system.

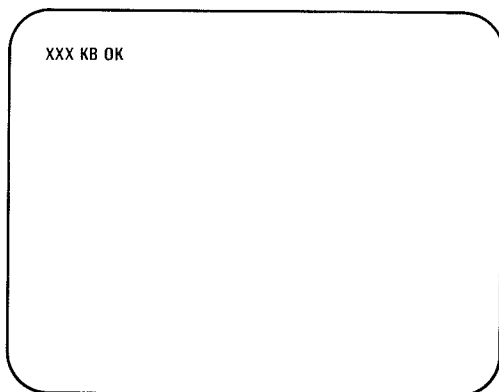

- B** One short beep will be heard when the test finishes successfully.
- C** The “IBM Personal Computer BASIC” message should appear. (If, at the end of POST, a program from a diskette, or an operating system from the fixed disk drive, is automatically loaded, the first screen presentation of the program or operating system should appear).

**The IBM Personal Computer Basic
Version CX.XX Copyright IBM Corp. XXXX
XXXXX Bytes free
Ok**

1LIST 2RUN 3LOAD 4SAVE 5CONT 6LPT1 7TRON 8TROFF 9KEY 0SCREEN

Did **A**, **B**, and **C** occur?

YES - Go to “Formatting a Diskette” on page Start 40-1.

NO - Personal Computer users go to “Personal Computer POST Errors” on the next page.

Personal Computer XT users go to “Personal Computer XT POST Errors” on Start 30-8.

Personal Computer POST Errors

In the following examples, find your screen response and audio response, then follow the instructions in the box marked "Action."

Warning: If the instructions are to have a unit serviced, and that unit has a fixed disk drive, we recommend that you back up all disk files onto diskettes. Normal shipping and handling can result in permanent loss of data on your fixed disk drives. Refer to the IBM *DOS* manual for a description of the Backup command.

Example 1

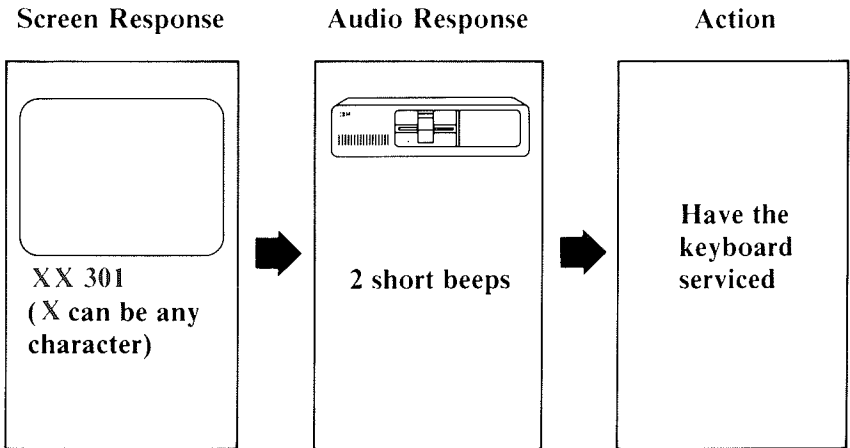

Note: Ensure the keyboard is connected correctly and check for any objects or foreign material on the keyboard. If error 301 still appears after the keyboard has been serviced, have the system unit serviced.

Example 2

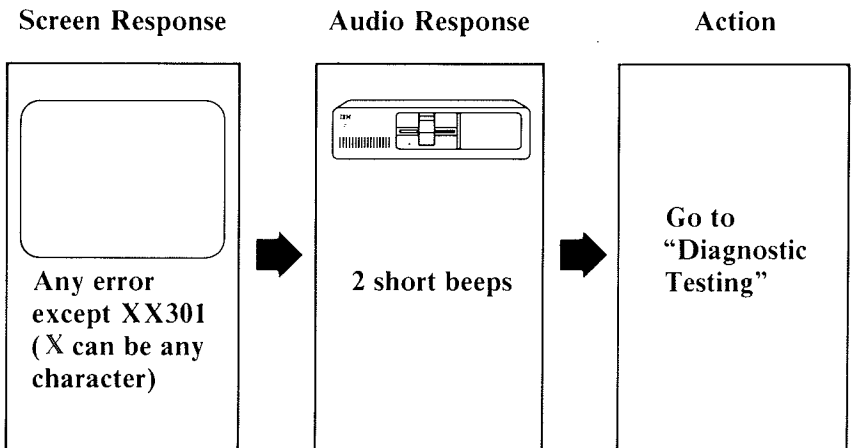

Example 3

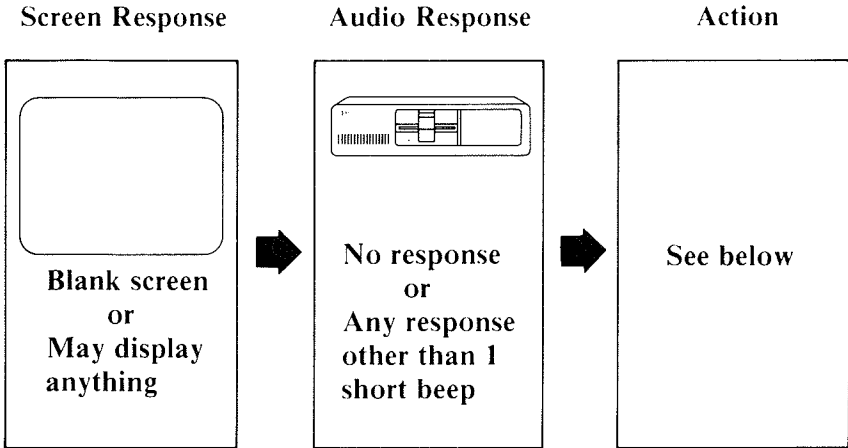

Do you have an expansion unit attached?

NO - Have the system unit serviced.

YES - Do the following:

1. Set the Power switches on the system unit and expansion unit to Off.
2. Set the Power switches on all attached devices to Off.
3. Disconnect the expansion unit cable from the system unit.
4. Set the Power switch on the system unit to On.

If the error is the same, have the system unit serviced.
If the error changes, have the expansion unit and its cable serviced.

Example 4 (Color Display Only)

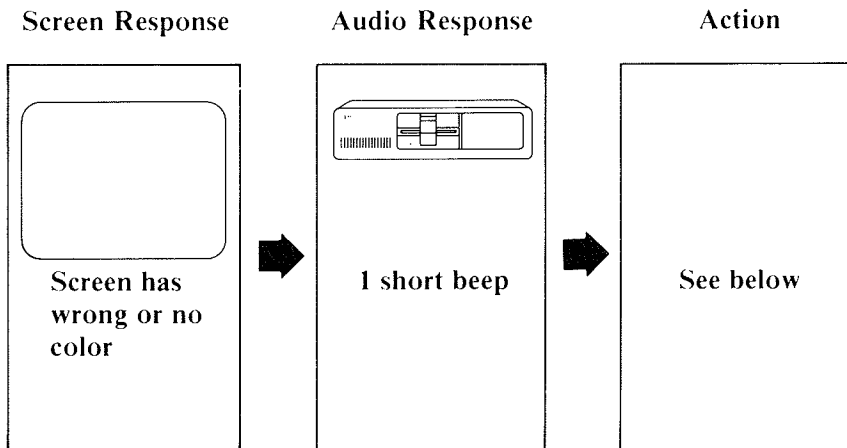

If you are using a TV as your display, verify that the color is correct by disconnecting your TV from the unit and operating the TV normally. Also, ensure your TV is compatible with the NTSC standard. If you have an IBM Color Display, go to Test 9000.

Example 5

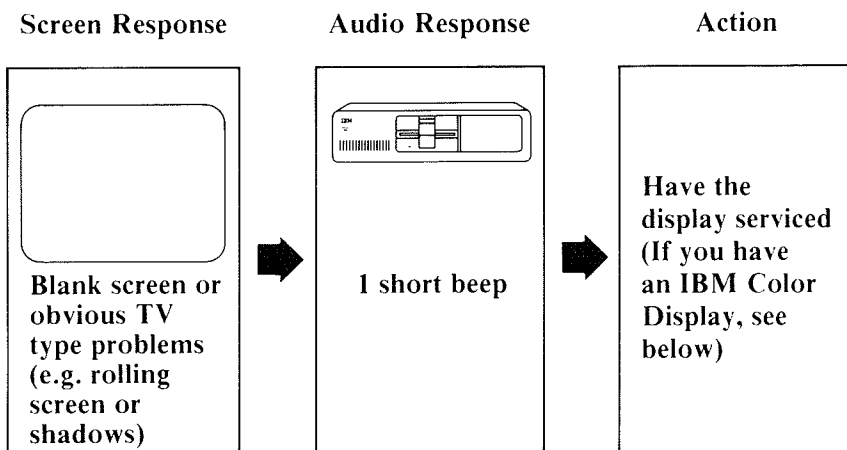

If you have an IBM Color Display, go to Test 9000.

Personal Computer XT POST Errors

In the following examples, find your screen response and audio response, then follow the instructions in the box marked "Action."

Warning: If the instructions are to have a unit serviced, and that unit has a fixed disk drive, we recommend that you back up all disk files onto diskettes. Normal shipping and handling can result in permanent loss of data on your fixed disk drives. Refer to the IBM *DOS* manual for a description of the Backup command.

Example 1

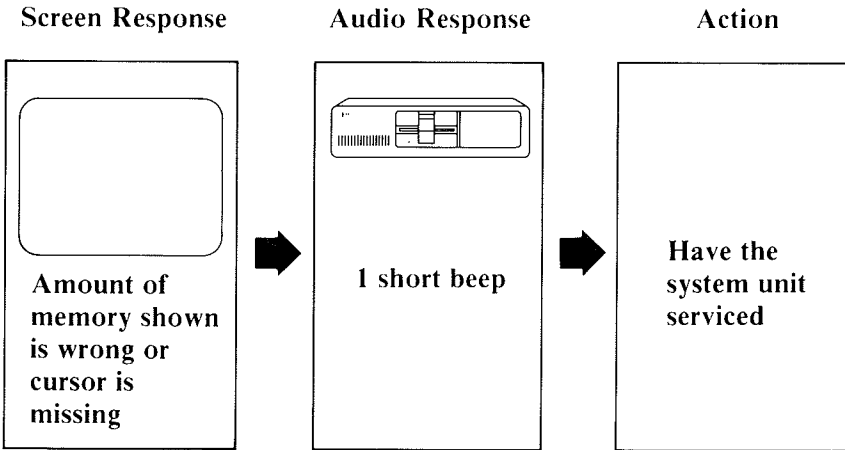

Example 2

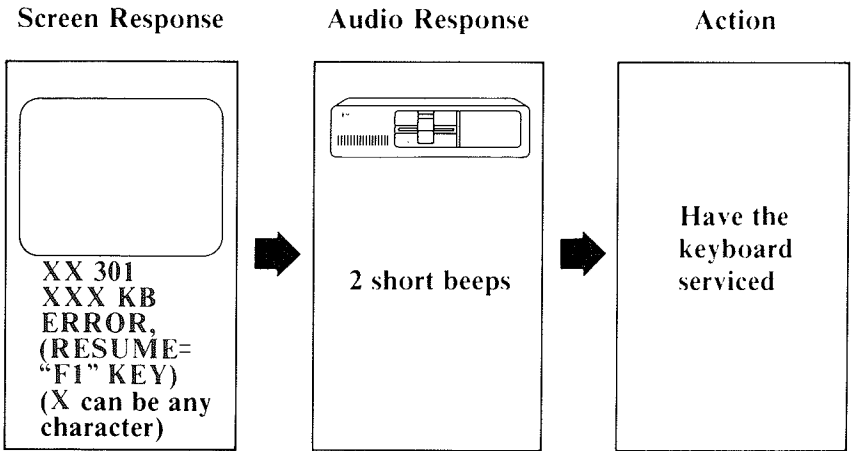

Note: Ensure the keyboard is connected correctly and check for any objects or foreign material on the keyboard. If error 301 still appears after the keyboard has been serviced, have the system unit serviced.

Example 3

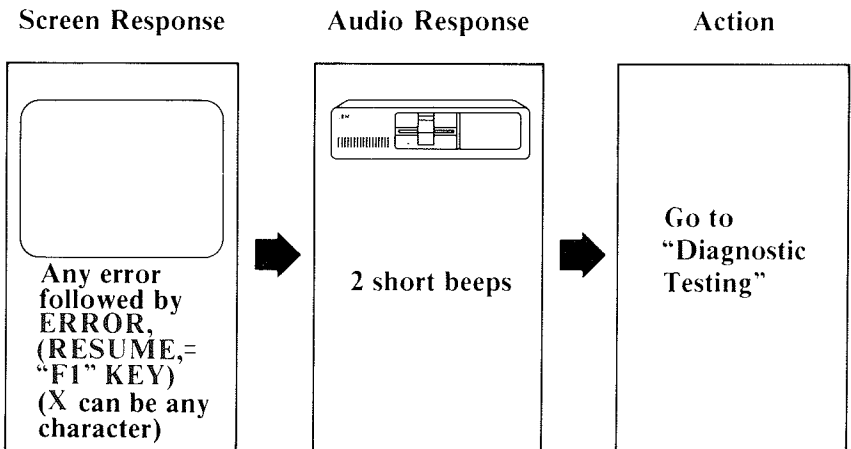

Example 4

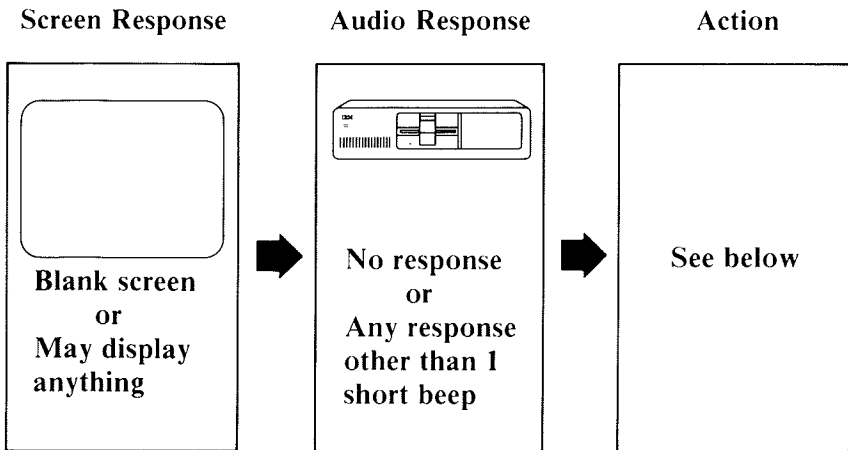

Do you have an expansion unit attached?

NO - Have the system unit serviced.

YES - Do the following:

1. Set the Power switches on the system unit and expansion unit to Off.
2. Set the Power switches on all attached devices to Off.
3. Disconnect the expansion-unit cable from the system unit.
4. Set the Power switch on the system unit to On.

If the error is the same, have the system unit serviced.
If the error changes, have the expansion unit and its cable serviced.

Example 5 (Color Display Only)

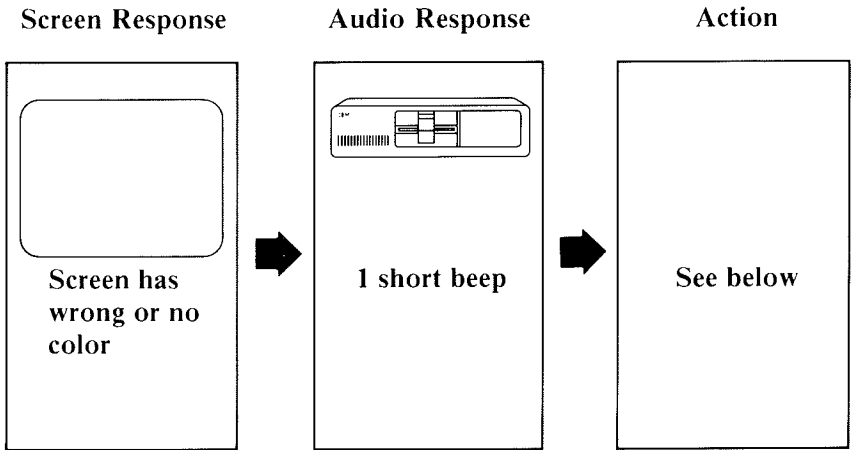

If you are using a TV as your display, verify that the color is correct by disconnecting your TV from the unit and operating the TV normally. Also, ensure your TV is compatible with NTSC standard. If you have an IBM Color Display, go to Test 9000.

Example 6

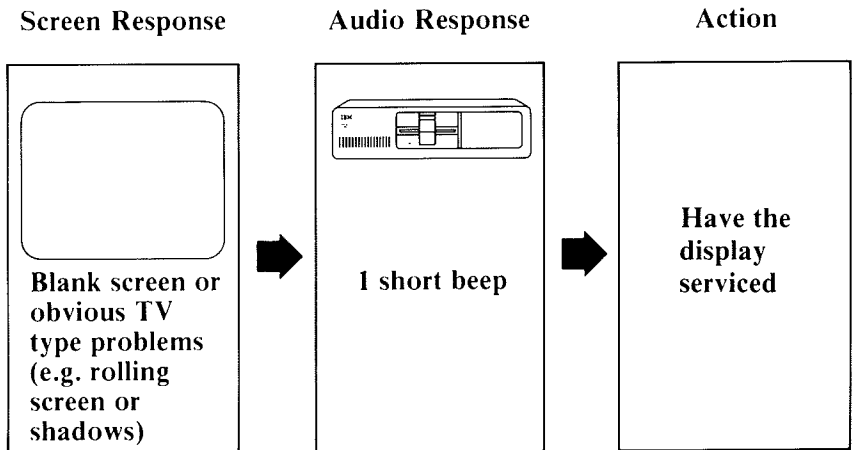

If you have an IBM Color Display, go to Test 9000.

Notes:

Formatting a Diskette

During the diagnostic tests that follow, you will need a scratch diskette (a *scratch* diskette is a formatted diskette with no data on it). If you already have a scratch diskette, skip this section and proceed to Diagnostic Testing on page Test 000-1. If you do not have a scratch diskette, continue with this procedure.

- 1** Remove the Diagnostics diskette from the back of this manual.

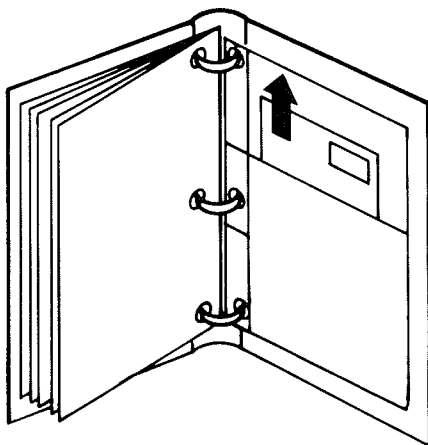

- 2** Set the Power switch on the system unit (and expansion unit, if attached) to Off.

- 3 Set the Power switches on all attached devices to Off.
- 4 Lift the diskette drive's load lever and insert the Diagnostics diskette into drive A.
- 5 Push the load lever down.

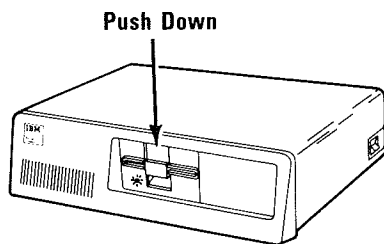

If you have trouble inserting your diskette, turn to the operating section of your *Guide to Operations* for more information.

- 6** Set the Power switches on all attached devices to On.
- 7** If an expansion unit is attached, set its Power switch to On.
- 8** Set the Power switch on the system unit to On.

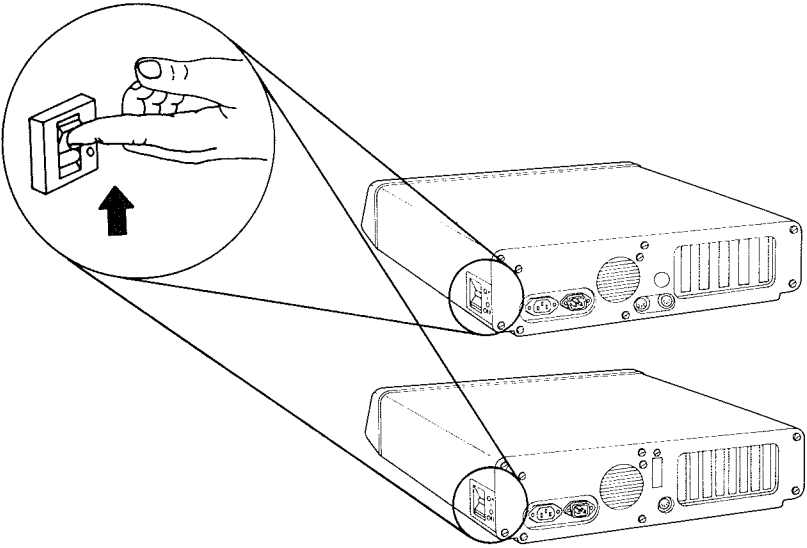

9 Did the following appear on your screen?

(X can be any character.)

XXXX
XXX KB OK
ERROR. (RESUME="F1" KEY)

YES - Press  , then go to the next step.

NO - Go to the next step.

10 Did the following appear on your screen?

**The IBM Personal Computer DIAGNOSTICS
Version XXX (C) Copyright IBM Corp XXXX, XXXX**

SELECT AN OPTION

0 - RUN DIAGNOSTIC ROUTINES

1 - FORMAT DISKETTE

2 - COPY DISKETTE

3 - PREPARE SYSTEM FOR RELOCATION

9 - EXIT TO SYSTEM DISKETTE

ENTER THE ACTION DESIRED

?

YES - Go to the next step.

NO - Remove the diskette and verify that it:

- Is the Diagnostics diskette.
- Was inserted correctly.

If the Diagnostics diskette was inserted correctly, have the system unit serviced.

11 Press  to select **FORMAT DISKETTE**,

then  .

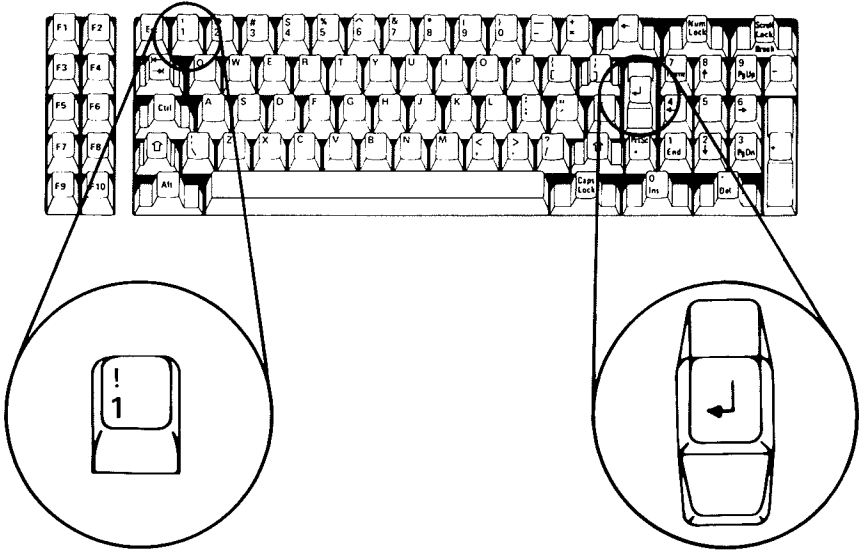

Go to the next step.

12 Did the following appear on your screen?

The IBM Personal Computer **DIAGNOSTICS**
Version XXX (C) Copyright IBM Corp XXXX, XXXX

SELECT AN OPTION

0 - RUN DIAGNOSTIC ROUTINES

1 - FORMAT DISKETTE

2 - COPY DISKETTE



3 - PREPARE SYSTEM FOR RELOCATION

9 - EXIT TO SYSTEM DISKETTE

ENTER THE ACTION DESIRED

? 1

**WHICH DRIVE CONTAINS DISKETTE
TO BE FORMATTED?**

YES - Press  then  and go to the
next step.

NO - Have your system unit serviced.

13 Did the following appear on your screen?

The IBM Personal Computer **DIAGNOSTICS**
Version XXX (C) Copyright IBM Corp XXXX
SELECT AN OPTION
0 - RUN DIAGNOSTIC ROUTINES
1 - FORMAT DISKETTE
2 - COPY DISKETTE
3 - PREPARE SYSTEM FOR RELOCATION
9 - EXIT TO SYSTEM DISKETTE
ENTER THE ACTION DESIRED
? 1
WHICH DRIVE CONTAINS DISKETTE
TO BE FORMATTED? A
INSERT DISKETTE TO BE FORMATTED
IN DRIVE A:
PRESS ENTER WHEN READY

YES - Remove the Diagnostics diskette from drive A, insert a blank diskette push the load lever down.

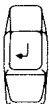
Press  and go to the next step.

NO - Have your system unit serviced.

14 The blank diskette will be formatted. When the In-Use light goes out, remove the scratch diskette and go to the next step.

- 15** Did the following appear on your screen after the diskette was formatted?

SELECT AN OPTION

0 - RUN DIAGNOSTIC ROUTINES

1 - FORMAT DISKETTE

2 - COPY DISKETTE

3 - PREPARE SYSTEM FOR RELOCATION

9 - EXIT TO SYSTEM DISKETTE

ENTER THE ACTION DESIRED

? - ✱ -

YES - Continue with “Diagnostic Testing” on page Test 000-1.

NO - Return to Step 10 and try another blank diskette. Be sure you insert the diskette correctly. If the problem still exists, have the system unit serviced.

Notes:

Diagnostic Testing

During the diagnostic tests that follow, you will need a scratch diskette. If you do not have a scratch diskette, go to "Diskette Format Procedure" on page Start 40-1.

During the diagnostic tests, you may be asked to record an error message. This information is needed when you have your system serviced.

Following are examples of error messages you may receive. **A message ending in 00 means the test finished successfully.**

In the examples, X can be any character.

Example 1

```
XX:XX:XX  
ERROR - SYSTEM UNIT  XXXX
```

Example 2

```
XX:XX:XX  
ERROR - EXPANSION UNIT  XXXX
```

The unit in which your options are installed determines if the error message reads **SYSTEM UNIT** or **EXPANSION UNIT**

Example 3

XX:XX:XX
XXX KB OK
ERROR. (RESUME="F1" KEY)

Warning: If the above message appears on your screen, it means the POST detected an error. The message also will appear if you have an expansion unit that is not connected to your system or that does not have its Power switch set to On.

Pressing the F1 key allows the system to bypass the error condition for the diagnostic tests, but your system may not function correctly unless it is serviced.

Continue with "Loading Diagnostics" on the next page.

Loading Diagnostics

- 1** Remove the Diagnostics diskette from the back of this manual.

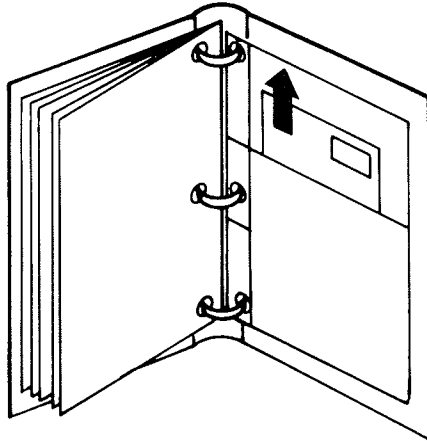

- 2** Set the Power switch on the system unit (and expansion unit, if attached) to Off.
- 3** Set the Power switches on all attached devices to Off.

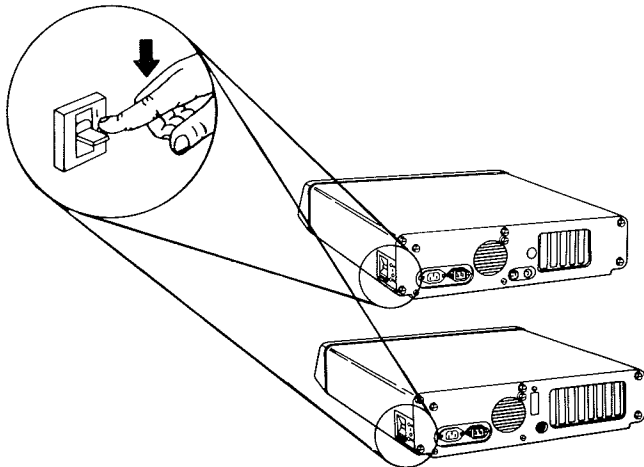

- 4** Raise the diskette drive's load lever and insert the Diagnostics diskette into drive A.
- 5** Push the load lever down.

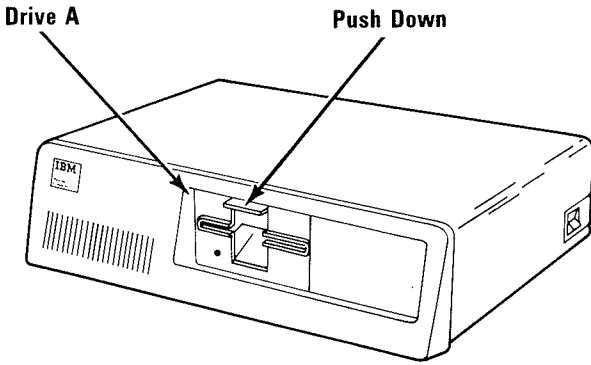

If you have trouble inserting your diskette, turn to the operating section of your *Guide to Operations* for more information.

- 6** Set the Power switches on all attached devices to On.
- 7** If an expansion unit is attached, set its Power switch to On.
- 8** Set the Power switch on the system unit to On.

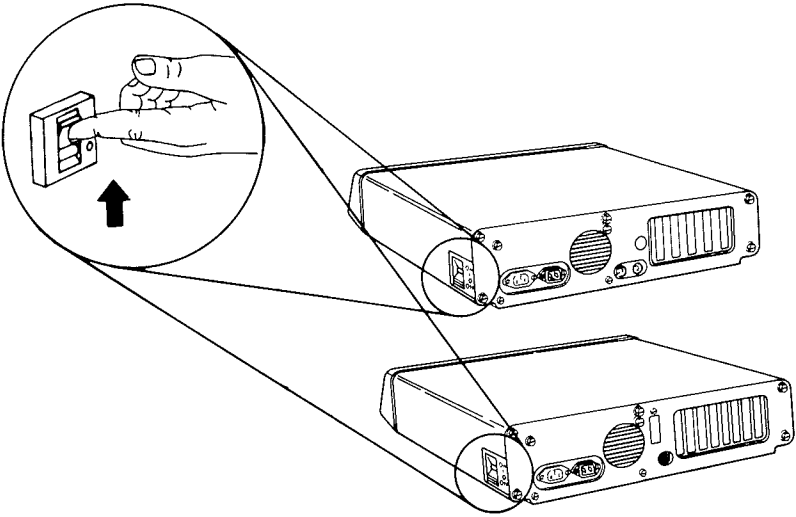

9

Did the following appear on your screen?

**XXXX
XXX KB OK
ERROR. (RESUME= "F1" KEY)**

YES - Press  , then go to the next step.

NO - Go to the next step.

10 Did the following appear on your screen?

The IBM Personal Computer DIAGNOSTICS
Version XXX (C) Copyright IBM Corp XXXX, XXXX
SELECT AN OPTION
0 - RUN DIAGNOSTIC ROUTINES
1 - FORMAT DISKETTE
2 - COPY DISKETTE
3 - PREPARE SYSTEM FOR RELOCATION
9 - EXIT TO SYSTEM DISKETTE
ENTER THE ACTION DESIRED
?



YES - Go to the next step.

NO - Remove the diskette and verify that it:

- Is the Diagnostics diskette.
- Was inserted correctly.

If the Diagnostics diskette was inserted correctly, have the system unit serviced.

Note: If you are using your TV or a non-IBM display, you could experience data errors when you operate your diskette drive. To correct this problem, move your TV or display a minimum of 30 cm (12 in.) away from your system unit.

11 Press , then  to select

RUN DIAGNOSTIC ROUTINES.

The IBM Personal Computer **DIAGNOSTICS**
Version XXX (C) Copyright IBM Corp XXXX



SELECT AN OPTION

- 0 - RUN DIAGNOSTIC ROUTINES**
- 1 - FORMAT DISKETTE**
- 2 - COPY DISKETTE**
- 3 - PREPARE SYSTEM FOR RELOCATION**
- 9 - EXIT TO SYSTEM DISKETTE**

ENTER THE ACTION DESIRED

?

Note: Depending on the configuration of your system, questions about attached devices may appear on your screen.

Press  or  as required,

then press .

- 12** Complete the list of installed devices and options and show their locations with check marks. Also enter the amount of memory you have in your system. Then go to the next step.

System Unit	Expansion Unit	Installed Device/Option
		System Board
		Expansion Option
		XXX KB of Memory
		Keyboard
		Monochrome and Printer Adapter
		X Diskette Drive(s) and Adapter
		Math Coprocessor
		X Fixed Disk Drive(s) and Adapter
		Asynchronous Communications Adapter

Installed Devices, Options, and Memory

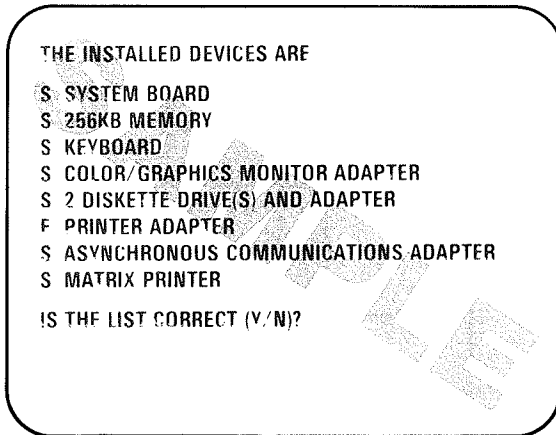

In the following sample, **S** means the device or option is installed in the system unit, and **E** means it is installed in the expansion unit.

- 13** Does the screen presentation correctly list all the installed devices and options?

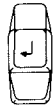

Note: The IBM Communications Cable and the Printer Cable will not appear in the list, and the Graphics Printer will be listed as "Matrix Printer." The Game Control Adapter may not be listed if the joysticks or paddles are not connected when the Power switch is set to On.

YES - Press  then  and go to the next step.

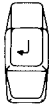
NO - Press  then , and record the error message. If your printer was not listed, press  and go to the next step. If any other device or option was not listed, have the unit that contains that option serviced.

14 Press  to select **RUN TESTS ONE TIME**,

then  .

SYSTEM CHECKOUT

- 0 - RUN TESTS ONE TIME**
- 1 - RUN TESTS MULTIPLE TIMES**
- 2 - LOG UTILITIES**
- 9 - EXIT DIAGNOSTIC ROUTINES**

ENTER THE ACTION DESIRED

?

The diagnostic programs have successfully loaded. Continue with the tests on the following pages to perform a complete system checkout.

Notes:

Test 100

Did you receive a **SYSTEM UNIT 100** message, as shown below?

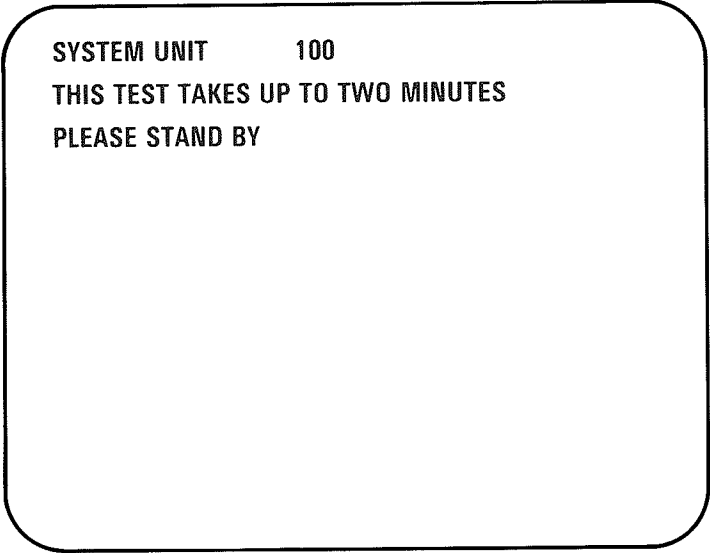

SYSTEM UNIT 100
THIS TEST TAKES UP TO TWO MINUTES
PLEASE STAND BY

YES - Your system has completed this test successfully. Continue with the next Test.

NO - Have the system unit serviced.

Notes:

Test 200

1 Do you have an IBM Expansion Unit attached to your system?

NO - Continue with the next Test, Test 300.

YES - Did you receive an **SYSTEM UNIT 1800** message, as shown below?

SYSTEM UNIT 100
SYSTEM UNIT 1800

THIS TEST TAKES UP TO TWO MINUTES
PLEASE STAND BY

YES - Your system has completed this test successfully. Continue with the next test, Test 300.

NO - Go to the next step.

- 2** Did you receive an **1819** error message, as shown below?

```
SYSTEM UNIT      100  
  
XX:XX:XX  
ERROR EXPANSION UNIT      1819  
  
PRESS ENTER TO CONTINUE  
?
```

YES - Have the expansion unit and its cable serviced.

NO - Go to the next step.

3

Did you receive an **1820** or **1821** error message?

SYSTEM UNIT 100

XX:XX:XX
ERROR EXPANSION UNIT 182X

PRESS ENTER TO CONTINUE
?

YES - Have the expansion unit and its cable serviced.

NO - Do the following:

1. Set the Power switches on the system unit and expansion unit to Off.
2. Set the Power switches on all attached devices to Off.
3. Disconnect the expansion-unit cable from the system unit.
4. Set the Power switch on the system unit to On.
5. Go to the next step.

- 4** When the POST finished, did the following appear on your screen?

1801



XXX KB OK

ERROR. (RESUME = "F1" KEY)

YES - Press  and go to the next step.

NO - Go to the next step.

5

Press , then  to select

RUN DIAGNOSTIC ROUTINES.

**The IBM Personal Computer DIAGNOSTICS
Version XXX (C) Copyright IBM Corp XXXX**



SELECT AN OPTION

- 0 - RUN DIAGNOSTIC ROUTINES**
- 1 - FORMAT DISKETTE**
- 2 - COPY DISKETTE**
- 3 - PREPARE SYSTEM FOR RELOCATION**
- 9 - EXIT TO SYSTEM DISKETTE**

ENTER THE ACTION DESIRED

? -  -

Note: Depending on the configuration of your system, questions about attached devices may appear on your screen.

Press  or  as required,

then press .



- 6** Are any of the options or devices installed in your expansion unit missing from the list?

THE INSTALLED DEVICES ARE

- S SYSTEM BOARD**
- S 256KB MEMORY**
- S KEYBOARD**
- S COLOR/GRAPHICS MONITOR ADAPTER**
- S 2 DISKETTE DRIVE(S) AND ADAPTER**
- E PRINTER ADAPTER**
- S ASYNCHRONOUS COMMUNICATIONS ADAPTER**
- S MATRIX PRINTER**

IS THE LIST CORRECT (Y/N)?

Note: The IBM Communications Cable and the Printer Cable will not appear in the list, and the Graphics Printer will be listed as "Matrix Printer." The Game Control Adapter may not be listed if the joysticks or paddles are not connected when the Power switch is set to On.

YES - Press  then  and go to the next step.

NO - Have the system unit serviced.

7

Press  to select

RUN TESTS ONE TIME, then .

SYSTEM CHECKOUT

0 - RUN TESTS ONE TIME

1 - RUN TESTS MULTIPLE TIMES

2 - LOG UTILITIES

9 - EXIT DIAGNOSTIC ROUTINES

ENTER THE ACTION DESIRED

?

Did you get an **1820** error message?

YES - Have the expansion unit and its cable serviced.

NO - Have the system unit serviced.



Notes:

Test 300

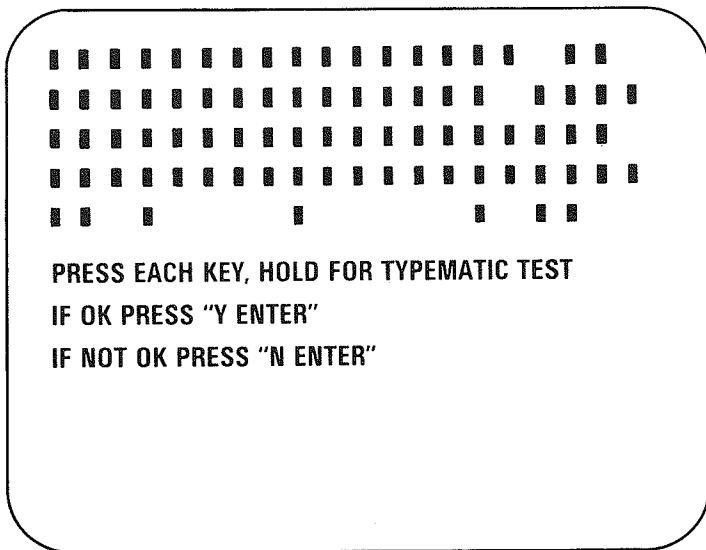
- 1** After approximately 2 minutes, did the following appear on your screen?



YES - Press each key once, then go to the next step.

NO - Press  then  . Record the

error message. Have the system unit serviced.

- 2 Did all the blocks change to characters as shown below?

1	2	←	1	2	3	4	5	6	7	8	9	Ø	-	=	↔	N	S		
3	4	⌞	Q	W	E	R	T	Y	U	I	O	P	[]		7	8	9	-
5	6	C	A	S	D	F	G	H	J	K	L	;	'	`	R	4	5	6	
7	8	S	\	Z	X	C	V	B	N	M	,	.	/	S	*	1	2	3	+
9	0	A						S						C	Ø	.			

PRESS EACH KEY HOLD FOR TYPEMATIC TEST
IF OK PRESS "Y ENTER"
IF NOT OK PRESS "N ENTER"

YES - Press and hold any key. The corresponding character on the screen will blink. This is the typematic test.

If the typematic test works correctly,

press  then  and go to the

next test. If the typematic test fails,

press  then . Record the

error message. Have the keyboard serviced.

NO - Have the keyboard serviced.

Test 400

1 Do you have an IBM Monochrome Display and Printer Adapter installed in your system?

NO - Continue with the next Test.

YES - Did the following appear on your screen?



```
XX:XX:XX  
ERROR SYSTEM UNIT 4XX
```

NO - Continue with the next step.

YES - Record the error message and have the unit that contains the adapter serviced.

2 Do you have an IBM Monochrome Display attached to the IBM Monochrome Display and Printer Adapter installed in your system?

NO - Continue with the next Test.

YES - Did the following appear on your screen?

DISPLAY ATTRIBUTES

THIS LINE IS AT NORMAL INTENSITY.



THIS LINE IS INTENSIFIED.



THIS LINE IS IN REVERSE VIDEO.

THIS LINE IS BLINKING

THIS LINE IS UNDERLINED

IS THE SCREEN CORRECT? (Y/N)

YES - Press  then  and go to the next step.

NO - Press  then . Record the error message and have the unit that contains the adapter serviced.



80X25 DISPLAY



```

!"###%&'()*+,-./0123456789:;<=>?@ABCDEFGHIJKLMN
!"###%&'()*+,-./0123456789:;<=>?@ABCDEFGHIJKLMNC
!"###%&'()*+,-./0123456789:;<=>?@ABCDEFGHIJKLMNOF
#%&'()*+,-./0123456789:;<=>?@ABCDEFGHIJKLMNOC
#%&'()*+,-./0123456789:;<=>?@ABCDEFGHIJKLMNODF
%&'()*+,-./0123456789:;<=>?@ABCDEFGHIJKLMNOCRE
&'()*+,-./0123456789:;<=>?@ABCDEFGHIJKLMNOCRSI
'()*+,-./0123456789:;<=>?@ABCDEFGHIJKLMNOCRSUJ
()*+,-./0123456789:;<=>?@ABCDEFGHIJKLMNOCRSUV
) *+,-./0123456789:;<=>?@ABCDEFGHIJKLMNOCRSUVV
*+,-./0123456789:;<=>?@ABCDEFGHIJKLMNOCRSUVVW>
+,-./0123456789:;<=>?@ABCDEFGHIJKLMNOCRSUVVWXY
,-./0123456789:;<=>?@ABCDEFGHIJKLMNOCRSUVVWXYZ
-./0123456789:;<=>?@ABCDEFGHIJKLMNOCRSUVVWXYZI
./0123456789:;<=>?@ABCDEFGHIJKLMNOCRSUVVWXYZI\
/0123456789:;<=>?@ABCDEFGHIJKLMNOCRSUVVWXYZI\`

```

IS THE SCREEN CORRECT? (Y/N)

YES - Press  then . Your system
has completed this test successfully.
Continue with the next Test.

NO - Press  then . Record the
error message and have the unit that
contains the adapter serviced.

Test 500

1 Do you have a color display or TV attached to your system?

NO - Continue with the next Test.

YES - Did the following appear on your screen?

DISPLAY ATTRIBUTES

THIS LINE IS AT NORMAL INTENSITY.

THIS LINE IS INTENSIFIED.

THIS LINE IS IN REVERSE VIDEO.

THIS LINE IS BLINKING.



BLUE



GREEN



CYAN



RED



MAGENTA







YELLOW



WHITE

IS THE SCREEN CORRECT ? (Y/N)

YES - Press  then  and go to the next step.



NO - Press  then . Record the error message and have the unit that contains the adapter serviced.



4 Did the following appear on your screen?

ADJ25 DISPLAY

```
! " # $ % & ' ( ) * + , - . / 0 1 2 3 4 5 6 7 8 9 : ; < = > ? @ A B C D E F G
! " # $ % & ' ( ) * + , - . / 0 1 2 3 4 5 6 7 8 9 : ; < = > ? @ A B C D E F G
" # $ % & ' ( ) * + , - . / 0 1 2 3 4 5 6 7 8 9 : ; < = > ? @ A B C D E F G H
# $ % & ' ( ) * + , - . / 0 1 2 3 4 5 6 7 8 9 : ; < = > ? @ A B C D E F G H I
$ % & ' ( ) * + , - . / 0 1 2 3 4 5 6 7 8 9 : ; < = > ? @ A B C D E F G H I J
% & ' ( ) * + , - . / 0 1 2 3 4 5 6 7 8 9 : ; < = > ? @ A B C D E F G H I J K
& ' ( ) * + , - . / 0 1 2 3 4 5 6 7 8 9 : ; < = > ? @ A B C D E F G H I J K L
' ( ) * + , - . / 0 1 2 3 4 5 6 7 8 9 : ; < = > ? @ A B C D E F G H I J K L M
( ) * + , - . / 0 1 2 3 4 5 6 7 8 9 : ; < = > ? @ A B C D E F G H I J K L M N
) * + , - . / 0 1 2 3 4 5 6 7 8 9 : ; < = > ? @ A B C D E F G H I J K L M N O
* + , - . / 0 1 2 3 4 5 6 7 8 9 : ; < = > ? @ A B C D E F G H I J K L M N O P
+ , - . / 0 1 2 3 4 5 6 7 8 9 : ; < = > ? @ A B C D E F G H I J K L M N O P Q
, - . / 0 1 2 3 4 5 6 7 8 9 : ; < = > ? @ A B C D E F G H I J K L M N O P Q R
- . / 0 1 2 3 4 5 6 7 8 9 : ; < = > ? @ A B C D E F G H I J K L M N O P Q R S
```

IS THE SCREEN CORRECT? (Y/N)

YES - Press  then  and go to the next step.

NO - Press  then  . Record the error message and have the unit that contains the adapter serviced.